



# Individual Vehicle Approval (IVA) Manual for Categories **01**, **02**, **03** and **04** (Trailers)



# Contents Page

Version Control	
Foreword	
03B Rear Protective Devices (Under Run)	
04 Rear Registration Plate Space	
05 Steering Effort	
09 Braking	
18 Statutory Plates	
20 Installation of Lights	
21 Retro Reflectors	
22 End-outline, Position (Side), Stop and Side Marker Lamps	
23 Direction Indicators	
24 Rear Registration Lamps	
28 Rear Fog Lamps	
29 Reversing Lamps	
36 Heating Systems	
42 Lateral Protection System (Side Guards)	
43 Spray Suppression	
45 Safety Glass	
46 Tyres	
48 Masses and Dimensions	
50A Couplings	
50B Couplings	
General Construction	
Glossary of Terms	



# Version Control

Section Number	Section Title	Revision Date	Revision Number
	Version Control	16/04/2009	1
		16/04/2009	1
03B	Rear Protective Devices (Under Run)	16/04/2009	1
4	Rear Registration Plate Space	16/04/2009	1
5	Steering Effort	16/04/2009	1
9	Braking	16/04/2009	1
18	Statutory Plates	16/04/2009	1
20	Installation of Lights	16/04/2009	1
21	Retro Reflectors	16/04/2009	1
22	End-outline, Position (Side), Stop and Side Marker Lamps	16/04/2009	1
23	Direction Indicators	16/04/2009	1
24	Rear Registration Lamps	16/04/2009	1
28	Rear Fog Lamps	16/04/2009	1
29	Reversing Lamps	16/04/2009	1
36	Heating Systems	16/04/2009	1
42	Lateral Protection System (Side Guards)	16/04/2009	1
43	Spray Suppression	16/04/2009	1
45	Safety Glass	16/04/2009	1
46	Tyres	16/04/2009	1
48	Masses and Dimensions	16/04/2009	1
50A	Couplings	16/04/2009	1
50B	Couplings	16/04/2009	1
	General Construction	16/04/2009	1
	Glossary of Terms	16/04/2009	1

## Version Control

This page intentionally left blank

# Foreword

This Manual is a detailed guide to the inspection of trailers submitted to an authorised inspection site under the Individual Vehicle Approval (IVA) scheme.

It is produced for the examiners who carry out the inspections and for trailer presenters and other interested parties who wish to familiarise themselves with the technical requirements and inspection procedures.

## Application

**The IVA scheme is one of three routes for a road vehicle to gain approval and thereby obtain licensing and registration in UK.**

The IVA route is open to vehicles falling under the following categories:

M1, M2, M3,  
N1, N2, N3  
O1, O2, O3, O4

This manual covers solely the IVA technical requirements for trailers of the following categories:

- O1,** Very Light Trailers, 0.75 Tonnes or less
- O2,** Light Trailer, Over 0.75 Tonnes up to 3.5 Tonnes
- O3** Medium Trailers, Over 3.5 Tonnes up to 10 Tonnes
- O4.** Heavy Trailers, Over 10 Tonnes

For information on other vehicle categories, the following VOSA IVA inspection manuals should be consulted.

- The Light Vehicle IVA Inspection Manual for vehicle category M1.
- The Light Goods Vehicle IVA Inspection Manual for vehicle category N1
- The Heavy vehicle IVA Inspection Manual for vehicle categories N2 and N3
- The Bus and Coach IVA Inspection Manual for vehicle categories M2 and M3

## Obligatory Approval certificates.

The IVA scheme is one of three routes for a new trailer to gain approval and thereby be legal for entry into service in UK. The other two routes are: European Whole Vehicle Type Approval (ECWVTA), and National Small Series Type approval (NSSTA). Refer to the Road Vehicles (Approval) Regulations 2009 (SI 2009 No. 717) for more information.

## Trailer entry into service

New procedures for trailer entry into service will apply from 29 October 2012 for trailers built in a single stage and 29 October 2013 for trailers built in more than one stage (multi-stage build). From these dates all new trailers will be required to hold a valid approval certificate under one of the three approval schemes.

The procedures for trailer entry into service differ depending on whether the trailer concerned is subject to annual roadworthiness testing by the Vehicle Operator Services Agency (VOSA). As a general guide, trailers are only subject to annual test if they are designed to carry goods, exceed 1020kg unladen weight and exceed 3500kg laden weight. In addition all *articulated* semi-trailers (which impose at least 10% of their load onto the towing vehicle) that are designed to carry goods, are subject to annual test.

## Trailers subject to annual test

For trailers that are currently subject to annual test, the trailer will need to be notified to VOSA **before** it is first placed on the road and used, and proof of a relevant approval certificate provided. (Although towing an unfinished trailer on the public road, to a place where the trailer will be finished, will be permitted, as long as no goods are carried).

## Trailers not subject to annual test

For trailers that are not subject to annual test, from the applicable dates there will be a legal obligation on the **retailer** to keep a record of all the trailers that he has sold, which are sufficient to identify the trailer and which include details of the approval certificate.

## Approval Process

There is only one level of compliance to the IVA Approval process for trailers.

“Normal IVA Requirements” applies to Trailers.

The standards applicable are those given in each section of this manual, and apply to trailers submitted for inspection on or after 29<sup>th</sup> April 2009.

# Foreword

The onus is on the applicant to provide evidence of compliance. This can, for example, be in the form of manufacturer's markings on the trailer, documentary evidence from the competent authority in the country of origin or the manufacturer, submission of a test report from an accredited technical service, test house or a combination of such elements, and it may also include a degree of visual examination and practical tests. Applicants may be required to dismantle certain parts of the trailer to allow VOSA examiners to carry out a full and meaningful inspection.

Applications and supportive documentation will be assessed prior to the issue of an appointment for inspection by Technical Services Branch. Examination of the trailer will include verification checks to confirm as far as possible compliance with the required standards.

### **Scope of Inspection**

**The design and construction requirements applicable to road vehicles are contained within the Road Vehicles (Approval) Regulations 2009. The inspection procedures within this manual have been developed to assess as far as practicable the ability of the vehicle to comply with those Regulations. This manual is however not a legal interpretation of the Regulations. The issue of an Approval Certificate should not be taken as absolute evidence that the vehicle can legally be used on the road, since there may be other applicable requirements contained in other regulations.**

**Examiners are not required to carry out a roadworthiness inspection but where obvious safety defects are noted the vehicle may be subject to prohibition action, The IVA certificate will not be issued and where applicable it may be indicated on the IVA 30 (refusal to issue a certificate) that a relevant section of the inspection was "Unable to be assessed fully" due to the condition of an item. i.e. In the case of tyres where any tyre displays cuts or damage or has a tread depth of less than 2 mm (the examiner may measure the depth as appropriate)**

### **Method of Inspection**

The examination will be limited to parts of the trailer which can be readily seen without dismantling. However, the driver might be required to open lockable compartments, remove covers, inspection/access panels, trims or carpeting, etc in order to gain access to items subject to examination.

The visual assessment of certain items e.g. overrun brake couplings (which in Type Approval undergo a physical test) might not always be sufficient to satisfy the examiners that the trailer complies with the requirements of the regulations. In such circumstances the onus is on the applicant to demonstrate that the trailer complies with the requirements of the regulations, for example, by the production of satisfactory test result documentation.

In some areas of the inspection, evidence that the trailer complies with the relevant criteria may be submitted in the form of documentation. This can, for example, be satisfactory evidence that the trailer complies with the relevant requirements of a European Directive

For any technical subject an appropriate type approval certificate or a test report from a recognised test house will be accepted as an alternative provided that the trailer can be identified as belonging to the type to which the documentation refers.

In certain cases calculations will be required to prove compliance. Where these are required they should be submitted with the application for inspection to VOSA, The Ellipse, Swansea, for verification prior to the inspection. Failure to produce these calculations may delay the inspection appointment being confirmed.

### **Use of this manual**

The manual has been arranged in the same order as the Recast Framework Directive (RFD) from which the inspection criteria is derived. Each inspection area broadly covers the requirements that trailers must meet or exceed based upon the National IVA scheme.

**General Construction is a section that does not explicitly exist in the RFD, rather it is implicit that unsafe trailers are not permitted to be approved.**

### **Use of a suitable towing vehicle**

All trailers presented for IVA Inspection must be accompanied by a suitable towing vehicle. The vehicle must be compatible with the type of trailer and so equipped to allow the operation of all lights and any braking fitted to the trailer. Its coupling must allow the trailer to be at its normal running attitude.

### **Refusal to examine**

The examination of a trailer may be refused for any of the following reasons

- the trailer is not submitted for examination at the time and place appointed
- the fee has not been paid
- the trailer is presented in a dirty or dangerous condition such as to make it unreasonable for the examination to be carried out
- a load or items on the trailer are not secured or removed as requested
- a proper examination cannot be carried out because any door or other device designed to be readily opened cannot be opened
- the condition of the trailer (in the opinion of the examiner) is such that proper examination of the trailer would involve a danger of injury to any person or damage to the trailer or any other property
- the trailer does not display, permanently, in an accessible position and readily legible, the required “ stamped – in” trailer identification number
- the driver does not remain in the vehicle or its vicinity and operate the controls, drive the vehicle or to remove/refit panels as requested to allow a meaningful examination of the trailer.
- Unsuitable towing vehicle

<b>Summarised Table of requirements for Trailers</b>							
<b>IVA Item Number</b>	<b>Directive Requirement</b>	<b>As amended by</b>	<b>UNECE Regulation</b>	<b>O1</b>	<b>O2</b>	<b>O3</b>	<b>O4</b>
<b>3B Rear Under-run</b>	70/221/EEC	2006/20/EC	58.01			Approval & Ins	Approval & Ins
<b>4 Reg plate space</b>	70/222/EEC				Inspection	Inspection	Inspection
<b>5 Steering effort</b>	70/311/EEC	1999/7/EC		Inspection	Inspection	Approval	Approval
<b>9 Braking</b>	71/320/EEC	2002/78/EC		Approval	Approval	Approval	Approval
<b>18 Statutory Plates</b>	76/114/EEC	78/507/EEC.	Inspection	Inspection	Inspection	Inspection	Inspection
<b>20 Installation of lights</b>	76/756/EEC		48.03	Inspection	Inspection	Inspection	Inspection
<b>21 Retro reflectors</b>	76/757/EEC	97/29/EC		Inspection	Inspection	Inspection	Inspection
<b>22 Side &amp; stop lights</b>	76/758/EEC	97/30/EC		Inspection	Inspection	Inspection	Inspection
<b>23 Direction indicators</b>	76/759/EEC	99/15/EC		Inspection	Inspection	Inspection	Inspection
<b>24 Rear Reg lamp light</b>	76/760/EEC	97/31/EC		Inspection	Inspection	Inspection	Inspection
<b>28 Rear Fog lights</b>	77/538/EEC	99/14/EC		Inspection	Inspection	Inspection	Inspection
<b>29 Reverse lamps</b>	77/539/EEC	97/32/EC		Inspection	Inspection	Inspection	Inspection
<b>36 Heater systems</b>	2001/56/EC	2006/119/EC		Inspection	Inspection	Inspection	Inspection
<b>42 Side Guards</b>	89/297/EEC						Inspection
<b>43 Spray Suppression</b>	91/226/EEC						Inspection
<b>45 Safety glass</b>	92/22/EEC	2001/92/EC		Inspection	Inspection	Inspection	Inspection
<b>46 Tyres</b>	92/23/EEC	2005/11/EC		Inspection	Inspection	Inspection	Inspection
<b>48 Masses &amp; Dimensions</b>	97/27/EC	2003/19/EC		Inspection	Inspection Inspection	Inspection	Inspection
<b>50 Couplings</b>	94/20/EC				Inspection	Inspection	Inspection

Inspection

# Record of Revision

Revision	Date	Description of Change
1	16/04/2009	

## 03B Rear Protective Devices (Under Run)

**Application:** All Trailers of category O3 and O4

Method of Inspection	Required Standard
<p>Ensure the trailer or device <b>as presented</b> is accompanied by satisfactory evidence in the form of:</p> <ul style="list-style-type: none"> <li>• a type approval</li> </ul> <p><b>(If a valid trailer approval relating to the trailer in its finished un modified state is provided the installation check is not required)</b></p> <p>or</p> <ul style="list-style-type: none"> <li>• a test report witnessed by the Approval Authority (VCA)</li> </ul> <p>or</p> <ul style="list-style-type: none"> <li>• evidence that calculations were provided at the time of application to the satisfaction of the Approval Authority. (VCA)</li> </ul> <p><b>And</b> in these cases an Installation check is required</p> <p><b>Note 1:</b> Evidence may be for a trailer, a separate device or that the rear of the trailer is so designed as to perform the same function. Where the rear body is so designed <b>the Installation Inspection as appropriate relates to the structure forming the rear of the trailer.</b></p> <p><b>Note 2:</b> The width of the rear axle is measured at the outermost points of the wheels including the tyres (excluding any tyre bulging close to the ground). Where more than one rear axle is fitted the width used is that of the widest axle</p>	<p><b>Approval</b></p> <ol style="list-style-type: none"> <li>1. The trailer <b>as presented</b> must be accompanied by satisfactory evidence of compliance regarding the protective system (see note1)</li> <li>2. Separate devices must be correctly marked and be as specified in the approval / test report or calculation documents.</li> </ol> <p><b>Installation check (see note 1)</b></p> <ol style="list-style-type: none"> <li>3. Where a separate device is fitted it must be fitted as per manufacturer's instructions.</li> <li>4. The lower edge of the rear under-run must at no point be more than 550mm above the ground.</li> <li>5. The width of the rear under-run must not extend beyond the width of the rear axle. (see notes 2 and 3)</li> <li>6. The width of the rear under-run must extend to within 100mm of the width of the rear axle on either side (see notes 2 and 3)</li> <li>7. The rear under-run criteria must be met as close to the rear of the trailer as possible</li> <li>8. The section height of the rear under-run must not be less than 100mm</li> </ol>

## Rear Protective Devices (Under Run) 03B

Method of Inspection	Required Standard
<p><b>Note 3:</b> Where the rear under-run is combined with a tail lift the lift structure may extend beyond the width of the rear axle to the width of the body, the requirements for the rear under run will be considered to be met providing the “device” meets all other dimensions up to the width of the rear axle.</p>	<ol style="list-style-type: none"> <li>9. The outer ends of the rear under-run must be rounded on the outside and have a radius of curvature of not less than 2.5mm.</li> <li>10. Rear under run must be securely attached to the rear of the trailer</li> <li>11. Rear under-run or mountings must clearly be of adequate strength to perform their function.</li> <li>12. In the case of a movable rear under-run, the device must be able to be securely locked into the service position.</li> <li>13. In the case of a movable rear under-run, the locking mechanism must be clearly of adequate strength to enable the device to perform its function</li> </ol> <p><b>Where platform lifts are incorporated into the under-run</b></p> <ol style="list-style-type: none"> <li>14. The lateral distance between working elements of the lift and fixed elements of rear under-run must be a maximum of 25mm</li> <li>15. Each individual section of the rear under-run-must have a rear facing surface area of at least 350cm<sup>2</sup></li> </ol>

## Rear Protective Devices (Under Run) 03B

2 of 4

## Record of Revision

Revision	Date	Description of Change
1	16/04/2009	

This page intentionally left blank

## 04 Rear Registration Plate Space

**Application:** All Trailers

Method of Inspection	Required Standard												
<p>All trailers must have a suitable place to mount a rear registration plate.</p> <p><b>Trailers which are approved to Directive 70/222/EEC will not require an inspection to this section, providing the trailer has not been modified.</b></p> <p><b>Note 1:</b> A plate hanging from the trailer with no structure or support brackets behind it would be considered unacceptable</p> <p><b>Note 2:</b> With an “IVA Test” plate of the required size placed onto the space provided, check that it is visible and that the whole of the yellow shaded portion can be easily seen from a height of 1.5m from all points along a 21.5m line on the ground placed at 10.75m (centralised to the centre of the available rear reg plate space) behind and parallel to the rear of the trailer.</p> <p><b>Note 3:</b> Rear registration plate mounting channels are permitted, these channels will hold the plate in place using the long edge of the plate but will still allow the registration mark to be displayed.</p>	<ol style="list-style-type: none"> <li>1. All trailers must comply with one of the “options” listed in table 1.</li> <li>2. The space must permit the mounting of a plate in a position as close to vertical as is permitted by the trailer structure available.</li> <li>3. An external body surface or a purpose-designed mounting system securely attached to the trailer must be provided to hold the plate in a fixed position. (see note 1)</li> <li>4. The whole of the yellow shaded portion of the “IVA Test plate must be capable of being easily seen from every point along the test line. (see note 2)</li> </ol> <p><b>Table 1</b></p> <table border="1" data-bbox="1151 995 2063 1102"> <thead> <tr> <th></th> <th></th> <th>Width</th> <th>Height</th> </tr> </thead> <tbody> <tr> <td>Euro space</td> <td>Option 1</td> <td>520</td> <td>120</td> </tr> <tr> <td></td> <td>Option 2</td> <td>340</td> <td>240</td> </tr> </tbody> </table>			Width	Height	Euro space	Option 1	520	120		Option 2	340	240
		Width	Height										
Euro space	Option 1	520	120										
	Option 2	340	240										

## Rear Registration Plate Space 04

### Record of Revision

Revision	Date	Description of Change
1	16/04/2009	

### Rear Registration Plate Space 04

## 05 Steering Effort

**Application:** All Trailers of category O3 and O4 if fitted with steered axles

Method of Inspection	Required Standard
Ensure the trailer has satisfactory evidence of compliance to the required standard	<ol style="list-style-type: none"><li data-bbox="1196 424 2063 517">1. The trailer <b>as presented</b> must be accompanied by satisfactory evidence of compliance with the required standard for Steering Effort</li></ol>

### Record of Revision

Revision	Date	Description of Change
1	16/04/2009	

## 09 Braking

**Application:** All Trailers of category O2, O3 and O4 (O1 if equipped with a braking system)

Method of Inspection	Required Standard
<p>Ensure that the trailer <b>as presented</b> has satisfactory evidence of compliance to the required standard</p> <p><b>O2 trailers and O1 trailers equipped with a braking system</b></p> <p>Check that a test report for the foundation brake, the coupling, and a compatibility report are provided</p> <p>Check that a breakaway cable is fitted to all trailers and is fitted with an attachment device such as a snap clip, carabena or shackle.</p> <p><b>Note 1:</b> The braking systems shall be such that the trailer is stopped automatically if the coupling separates while the trailer is in motion. However, this requirement does not apply to trailers with a maximum mass not exceeding 1,5 metric tons provided that the trailers are fitted, in addition to the main coupling, with a secondary coupling</p>	<p>1. The trailer <b>as presented</b> must be accompanied by satisfactory evidence of compliance with the required standard for "Braking".</p> <p><b>O2 trailers and O1 trailers equipped with a braking system</b></p> <p>2. A breakaway cable must be fitted to the trailer if over 1500kg (see note 1)</p> <p>3. A breakaway cable must be able to apply the trailer brakes in the event of detachment.</p> <p>4. The breakaway cable must be fitted with an attachment device that enables the cable to be fitted to any suitable drawing vehicle.</p> <p>5. A breakaway cable must be fitted with a guide to ensure that the brake is applied with the trailer at any towing angle in the event of detachment</p>

## Braking 09

# Record of Revision

Revision	Date	Description of Change
1	16/04/2009	

# 18 Statutory Plates

**Application:** All Trailers

Method of Inspection	Required Standard
<p>Check the trailer is provided with a compliant manufacturer's plate/s, and a compliant permanently marked Trailer Identification number in the chassis</p> <p>Where the trailer is subject to a multistage build, a plate is required on completion of each stage as appropriate; every plate fitted must display the same Trailer Identification number (Chassis number) as displayed on the chassis.</p> <p>The weight information is only necessary on the chassis manufacturer's plate or on a converters plate if they have altered those weights with any modification.</p> <p>The manufacturer may give additional information. A type approval number may be listed below the manufacturer's name. The number of axles may be listed underneath the Trailer Identification number. Any other information must be outside a clearly marked rectangle which shall enclose only the mentioned information.</p> <p>If any of the technically permissible masses are higher than the masses permitted in GB and NI for a trailer or axle (see Annex 1 for details of the maximum masses permitted in GB and NI), then there should be 2 columns for masses - in the left hand column the maximum permitted masses in GB/NI, and in the right hand column, the technically permissible masses. This does not apply to a trailer issued with a Plating certificate under the Goods Vehicles (Plating and Testing) Regulations 1988 where only one column, giving the technically permissible masses, is permitted. (See Section 48 Masses and Dimensions for requirements for a plating certificate )</p>	<ol style="list-style-type: none"> <li>1. The trailer must be fitted with a manufacturer's plate in a conspicuous and readily accessible position</li> <li>2. A manufacturer's plate must be fitted for each stage of a multistage build.</li> <li>3. The manufacturer's plate(s) must be made of a durable material</li> <li>4. The manufacturer's plate must be securely attached to the trailer that will not be replaced through normal use. (See note 1)</li> <li>5. The manufacturer's plate(s) must be indelibly marked with the Trailer Identification Number which matches the number marked into the trailer structure. (See notes 2)</li> <li>6. The manufacturer's plate(s) must show the following required information in the correct order:- (See note 2) <ul style="list-style-type: none"> <li>• Name of manufacturer</li> <li>• Trailer Identification Number</li> <li>• Maximum permitted laden mass of trailer</li> <li>• Maximum permitted laden road mass for each axle, listed in order from front to rear</li> <li>• In the case of a <b>semi trailer</b>, the maximum permitted mass on the fifth wheel kingpin.</li> <li>• in the case of <b>O1 trailers</b>, the year of manufacture (optional for other categories)</li> </ul> </li> </ol>

## Statutory Plates 18

Method of Inspection	Required Standard
<p><b>Note 1:-</b>'Firmly attached' means screwed, bolted, riveted or otherwise fixed such that it is not likely to become displaced during the life of the trailer.</p> <p><b>Note 2:-</b> For markings to be considered 'indelible' they should be unlikely to become disfigured or obliterated during the life of the trailer. Whilst stamping or engraving is preferable it is possible to accept a printed or painted plate providing it has been treated in such a way that it is most unlikely that essential information would be obliterated or defaced during the normal life of the trailer.</p> <p><b>Note 3:</b> The spacing of characters must be such that no additional characters could be added at a later date.</p>	<ol style="list-style-type: none"> <li>7. The characters on the manufacturer's plate must be at least 4mm high.</li> <li>8. The Trailer Identification number must be marked on the chassis, frame or other similar structure on the right hand side of the trailer. (as viewed from the rear of the trailer)</li> <li>9. The Trailer Identification number must consist of 17 digits with the information shown in a single line.</li> <li>10. The Trailer Identification number must be placed in a clearly visible and accessible position by a method such as hammering or stamping so that it can not be obliterated or deteriorate.</li> <li>11. Capital letters and numerals must be used for the manufacturers name and Trailer Identification number</li> <li>12. There must not be any gaps between the characters for the Trailer Identification number shown on the manufacturer's plate or stamped into the trailer. (see note 3)</li> <li>13. The characters used for the Trailer Identification number stamped into the chassis, frame or other similar structure must be at least 7mm high.</li> <li>14. Use of the letter I, the letter O, the letter Q and dashes, asterisks and other special signs is not permitted.</li> </ol>

**Annex 1**  
**Maximum permitted weights in Great Britain and Northern Ireland**

Trailers	Weight (GVW)
O1	Up to 750kg (0.75 tonnes)
O2	751kg (0.75 tonnes) up to 3500kg (3.5 tonnes)
O3	3501kg (3.5 tonnes) up to 10000kg (10.0 tonnes)
O4	10001kg (10.0 tonnes) +
Axles	Weight
<b>Single axle</b>	10 tonnes
<b>Tandem axles of trailers and semi-trailers</b>	
	The <b>sum</b> of the axle weights must not exceed
Distance between axle centres is less than 1metre	11 tonnes
from 1metre and less than 1.3metres	16 tonnes
from 1.3metres and less than 1.8metres	18 tonnes
1.8metres or more	20 tonnes
<b>Tri-axle trailers and semi-trailers</b>	
	The <b>sum</b> of the axle weights must not exceed
from between axle centres 1.3metres or less	21 tonnes
from 1.3metres and up to 1.4metres	24 tonnes

# Record of Revision

Revision	Date	Description of Change
1	16/04/2009	

## 20 Installation of Lights

**Application:** All Trailers

Method of Inspection	Required Standard
<p>The examiner will perform a visual check of all lamps and reflectors fitted to the trailer to ensure the correct colour light is visible to the front or rear and that no light emitting surfaces are obscured</p> <p><b>Note 1:</b> Lamp/reflector <b>lateral position</b> is measured from the extreme outer edge of the trailer (disregarding tyres, mirrors, lamps and reflectors) to the edge of the illuminated area (or reflective surface on a reflector) nearest that side of the trailer.</p> <p>Lamp/reflector <b>vertical position</b> is measured from the ground;</p> <p>In the case of the <b>maximum</b> height to the top edge of the illuminated area (reflective surface on a reflector).</p> <p>In the case of the <b>minimum</b> height to the lower edge of the illuminated area (reflective surface on a reflector).</p>	<ol style="list-style-type: none"> <li>1. The trailer must be fitted with lamps or retro reflective material only capable of showing a white light to the front except for: <ul style="list-style-type: none"> <li>• an amber light from a direction indicator</li> <li>• an amber light from a side marker light</li> <li>• an green light from a ABS light</li> </ul> </li>   <li>2. The trailer must be fitted with lamps or retro reflective material only capable of showing a red light to the rear except for: <ul style="list-style-type: none"> <li>• an amber light from a direction indicator</li> <li>• a white light from a work lamp, reversing lamp, interior lamp, or a registration plate lamp</li> <li>• a yellow light from a rear registration plate</li> <li>• an amber light from a side marker light</li> <li>• emergency vehicles only, a blue light from an external warning lamp or beacon.</li> </ul> </li>   <li>3. All obligatory and optional lamps, reflectors and rear markers must be securely fitted to the trailer and not move by swivelling, deflecting, or otherwise while the trailer is in motion, except for a work lamp, used to illuminate a working area or the scene of an accident, breakdown or road works in the vicinity of the trailer to which it is fitted.</li> </ol>

## Installation of Lights 20

Method of Inspection	Required Standard
	<p data-bbox="1227 236 2069 296">4. All obligatory and optional lamps, reflectors and rear markers must be fitted to their correct orientation</p> <p data-bbox="1227 336 2119 435">5. When every door or other movable part is in the fixed open position (any position in which the component will remain, with or without a fixed stay) the</p> <ul data-bbox="1274 475 1688 574" style="list-style-type: none"><li data-bbox="1274 475 1688 505">• front and rear position lamps</li><li data-bbox="1274 509 1626 539">• front and rear indicators</li><li data-bbox="1274 542 1568 572">• rear retro reflectors</li></ul> <p data-bbox="1274 612 1812 643">must fulfil one of the following conditions:</p> <p data-bbox="1267 683 2092 743">a. half (50%) of the apparent surface of the lamp or reflector is visible from directly behind the trailer, <b>or</b></p> <p data-bbox="1267 783 2092 876">b. additional fully visible lamp (s) / reflectors satisfying all requirements for the above lamps / reflectors are activated / visible, <b>or</b></p> <p data-bbox="1267 916 2125 1050">c. a notice on the trailer must inform the user that in certain positions of the movable components, other road users should be warned of the presence of the trailer on the road (e.g. by laying out a warning triangle).</p>

## Installation of Lights 20

**Figure 1**  
**Horizontal Angles of Visibility**

Each lamp and reflector must be positioned such as to provide an “apparent surface”. At least 50% of the “apparent surface” of each lamp or reflector must be visible from any point within the relevant angles.

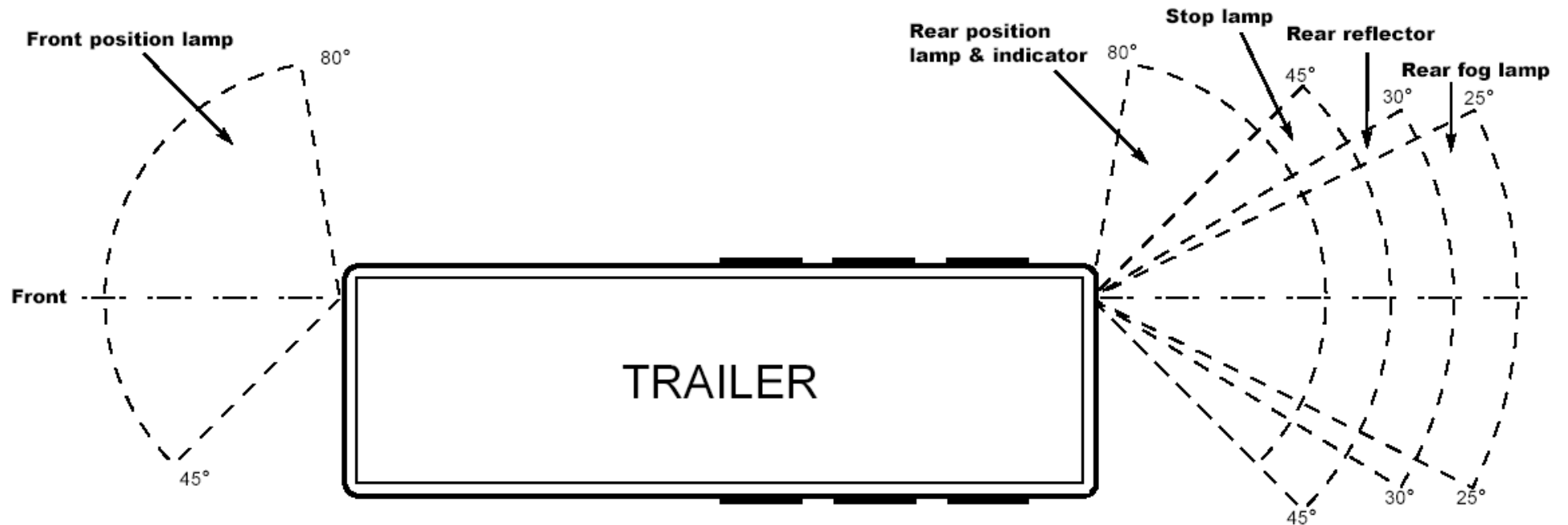

## Installation of Lights 20

## Figure 2 Vertical Angles of Visibility

Front Position Lamps and Indicators (including Side Repeaters)

'a' = less than 750mm above ground level.

'b' = 750mm or more above ground level.

'c' = Rear position lamps and Stop lamps 1500mm or more above ground level. Indicators and Rear reflectors 750mm or more above ground level.

'd' = Rear position lamps and Stop lamps less than 1500mm above ground level.

'e' = Rear position lamps, Stop lamps, Indicators and Rear reflectors less than 750mm above ground level.

'f' = Rear fog lamps.

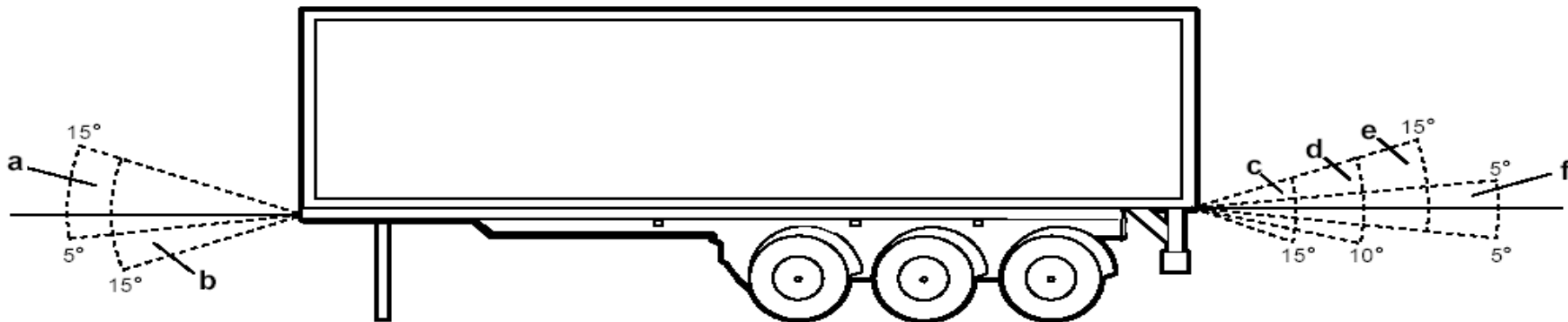

## Installation of Lights 20

**Figure 3**

“To the rear” of the trailer means “in an area the sides of which are at an angle of 15 degrees out from the extreme outer edge of the trailer, (starting from the rear corner) and extending up to **25m** from the rear of the trailer (measured along the trailer longitudinal).”

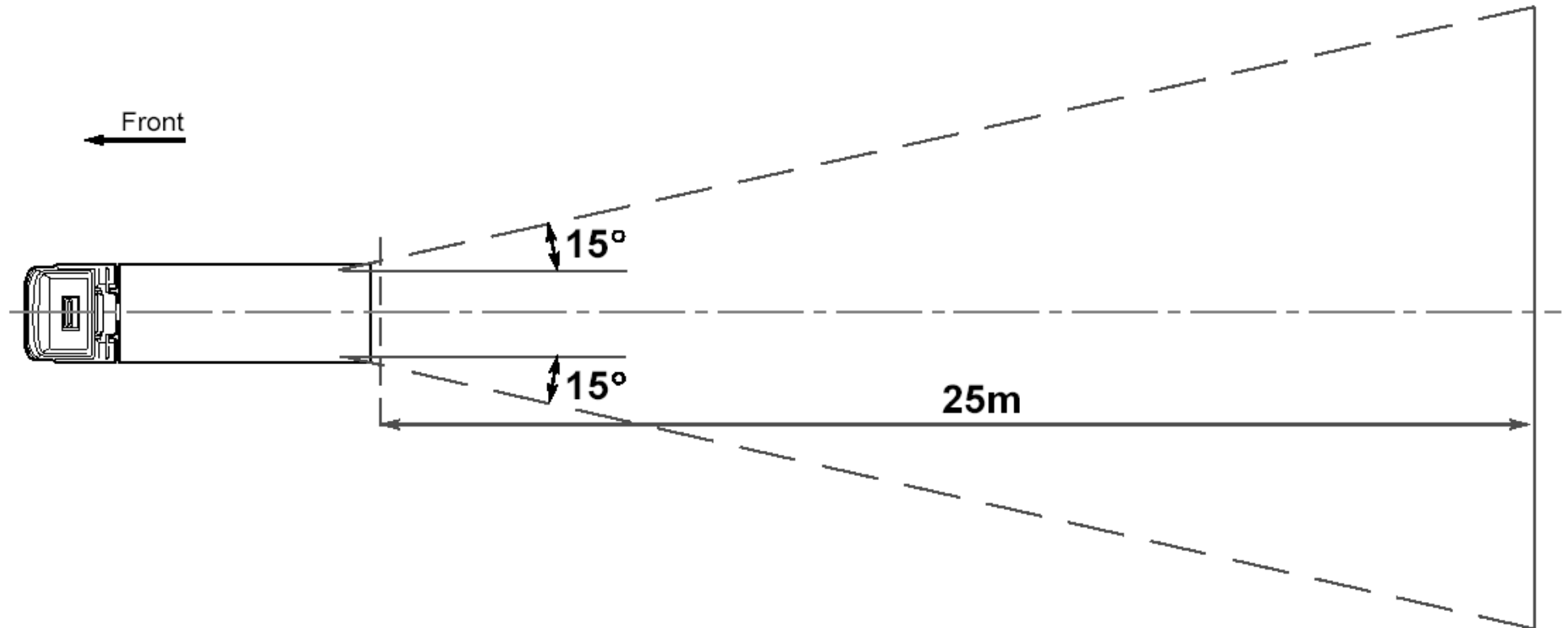
**Installation of Lights 20**

### Record of Revision

Revision	Date	Description of Change
1	16/04/2009	

## 21 Retro Reflectors

**Application:** All Trailers

Method of Inspection	Required Standard
<p>Carry out a check of all retro reflectors and rear markers fitted to the trailer for colour, number, approval marks and correct positioning. This also includes optional reflectors</p> <p><b>Note:</b> Geometric angles of visibility and positional requirements are not required for all optional reflectors.</p>	<p><b>Retro reflectors;</b></p> <ol style="list-style-type: none"> <li>1. All reflectors must be 'e' or 'E' marked and where applicable, bear the appropriate identity marking as listed in Table 1</li> <li>2. The correct number must be fitted to the trailer ( Table 1 )</li> <li>3. The correct colour must be fitted to the trailer ( Table 1 )</li> <li>4. They must be positioned to meet               <ol style="list-style-type: none"> <li>a. the positional requirements of Table 1</li> <li>b. the angles of visibility requirements of Table 1</li> </ol> </li> <li>5. They must be of the correct shape ( Table 1 )</li> </ol> <p><b>Rear Markers; (O1, O2 if over 8m in length and all O3 and O4)</b></p> <ol style="list-style-type: none"> <li>6. All rear markers must bear the appropriate approval marks</li> <li>7. A minimum of one set of obligatory markers must be fitted to the trailer ( Table 2 )</li> <li>8. They must be positioned correctly to meet the positional requirements of Table 2</li> <li>9. They must be of the correct type ( Table 2 )</li> </ol>

## Retro Reflectors 21

Table 1

TYPE	NUMBER	APPLICATION	COLOUR	POSITION			ANGLES OF VISIBILITY (see figure 1 & 2 of section 20)	APPROVAL MARK "E" or "e" Identity Symbol or BS Mark / Notes
				MAX DISTANCE FROM SIDE (mm)	MAX HEIGHT (mm)	MIN HEIGHT (mm)		
<b>Rear Retro Reflectors Triangular (Optional any shape)</b>	Min 2 Max any number Includes optional	Mandatory	Red	400 (Min separation 600 unless trailer width less than 1300, where Min separation 400)	900 or if impracticable 1500	250	a. Horizontal i. 30° inwards and outwards. b. Vertical i. < 750mm above the ground 15° above and 5° below horizontal. ii. otherwise 15° above and below horizontal	III or IIIA "E" or "e"
<b>Front Retro Reflectors Non-triangular</b>	Min 2 Max any number Includes optional	Mandatory	White	150	900 or if impracticable 1500	250	a. Horizontal i. 5° inwards and 30° outwards. b. Vertical i. < 750mm above the ground 15° above and 5° below horizontal. ii. otherwise 15° above and below horizontal	I or IA "E" or "e"
<b>Side Retro Reflectors Non-triangular</b>	See below	Mandatory on all trailers exceeding 6m in length	Amber The rearmost may be red if within 1m of the rear	N/A	1500 or if the shape of the bodywork makes it impossible 2100	250	a. Horizontal 45° to the front and to the rear b. Vertical i. < 750mm above the ground 15° above and 5° below horizontal. ii. otherwise 15° above and below horizontal	I or IA "E" or "e"
<ul style="list-style-type: none"> <li>• At least one side reflector fitted to the middle third of the trailer</li> <li>• The foremost side- reflector being not further than 3 m from the front</li> <li>• The distance between two adjacent side- reflectors shall not exceed 3m (if bodywork makes it impracticable this distance may be increased to 4m)</li> <li>• The distance between the rearmost side- reflector and the rear of the trailer shall not exceed 1 m</li> </ul>								

## Retro Reflectors 21

**Table 2**

<b>1. Description</b>	
A trailer if it forms part of a combination of vehicles the overall length of which does not exceed 11m:	A rear marking of a type shown in diagram 1, 2, 3 or 4 in Part III of this Section
A trailer if it forms part of a combination of vehicles the overall length of which exceeds 11m but does not exceed 13m:	A rear marking of a type shown in Part III of this Section
A trailer if it forms part of a combination of vehicles the overall length of which exceeds 13m:	A rear marking of a type shown in diagram 5, 6, 7 or 8 in Part III of this Section
<b>2. Position</b>	
Longitudinal:	At or near the rear of the trailer
A rear marking of a type shown in diagram 2, 3, 4, 6, 7 or 8 in Part III of this Section:	Each part shall be fitted as near as practicable to the outermost edge of the trailer so that no part of the marking projects beyond the outermost part of the trailer on either side
A rear marking of a type shown in diagram 1 or 5 in Part III of this Section:	The marking shall be fitted so that the vertical centre-line of the marking lies on the vertical plane through the longitudinal axis of the trailer and no part of the marking projects beyond the outermost part of the trailer on either side
Vertical:	The lower edge of every rear marking shall be at a height of not more than 1700mm nor less than 400mm above the ground whether the trailer is laden or unladen
<b>3. Visibility:</b>	Plainly visible to the rear
<b>4. Alignment:</b>	The lower edge of every rear marking shall be fitted horizontally. Every part of a rear marking shall lie within 20° of a transverse vertical plane at right angles to the longitudinal axis of the trailer and shall face to the rear
<b>5. Markings</b>	An approval mark to ECE Regulation 70
<b>6. Colour:</b>	Red fluorescent material in the stippled areas shown in any of the diagrams in Part III of this Section and yellow retro reflective material in any of the areas so shown, being areas not stippled and not constituting a letter.

## Retro Reflectors 21

### Part III

#### Rear markings prescribed for Trailers



## Record of Revision

Revision	Date	Description of Change
1	16/04/2009	

This page intentionally left blank

## 22 End-outline, Position (Side), Stop and Side Marker Lamps

**Application:** All Trailers

Method of Inspection	Required Standard
<p>Carry out a visual check of all outline marker, position, stop, side marker and daytime running lamps fitted to the trailer for operation, colour, number, approval marks and correct positioning. This includes all optional lamps.</p> <p>With optional lamps check that fitment is permitted and they do not exceed the maximum number of lamps of that type allowed to be fitted</p> <p><b>Note:</b> The inspection of end-outline marker lamps applies to the obligatory marker lamps fitted to trailers exceeding 2.10m in width</p> <p><b>Note:</b> The inspection of the side marker lamps applies to the obligatory lamps fitted to all trailers exceeding 6m in length</p> <p><b>Note:</b> Geometric angles of visibility and positional requirements are not required for all optional position lamps, stop lamps and end outline marker lamps.</p>	<ol style="list-style-type: none"> <li>1. All lamps must be 'e' or 'E' marked and where applicable, bear the appropriate identity marking as listed in table 1</li> </ol> <p><b>Front and Rear Position Lamps;</b></p> <ol style="list-style-type: none"> <li>2. The correct number must be fitted to the trailer ( Table 1 )</li> <li>3. They must be operational</li> <li>4. They must only emit white light to the front / red light to the rear</li> <li>5. They must be positioned to meet               <ol style="list-style-type: none"> <li>a. the positional requirements of Table 1</li> <li>b. the angles of visibility requirements of Table 1</li> </ol> </li> </ol> <p><b>Stop Lamps;</b></p> <ol style="list-style-type: none"> <li>6. The correct number must be fitted to the trailers ( Table 1 )</li> <li>7. They must be operational</li> <li>8. They must only emit red light</li> <li>9. They must only illuminate when the service brake is applied, and must extinguish when the service brake is released</li> </ol>

## End-outline, Position (Side), Stop and Side Marker Lamps 22

Method of Inspection	Required Standard
	<p>10. They must be positioned to meet:</p> <ul style="list-style-type: none"> <li>a. the positional requirements of Table 1</li> <li>b. the angles of visibility requirements of Table 1</li> </ul> <p><b>Side Marker lamps; ( if required )</b></p> <p>11. The correct number must be fitted to the trailer (in accordance to the positional requirements)</p> <p>12. They must be operational</p> <p>13. They must emit an amber light ( red is permitted if within 1 metre of the rear )</p> <p>14. They must be positioned to meet:</p> <ul style="list-style-type: none"> <li>the positional requirements of Table 1</li> <li>the angles of visibility requirements of Table 1</li> </ul> <p><b>End Outline Marker Lamps; ( if required )</b></p> <p>15. The correct number must be fitted to the trailer ( Table 1 )</p> <p>16. They must be operational</p> <p>17. They must only emit red light to the rear / white light to the front</p> <p>18. They must be positioned to meet:</p> <ul style="list-style-type: none"> <li>the positional requirements of Table 1</li> <li>the angles of visibility requirements of Table 1</li> </ul>

## End-outline, Position (Side), Stop and Side Marker Lamps 22

Table 1

TYPE	NUMBER	APPLICATION	COLOUR	POSITION			ANGLES OF VISIBILITY (see figure 1 & 2 of section 20)	APPROVAL MARK "E" or "e" Identity Symbol or BS Mark
				MAX DISTANCE FROM SIDE (mm)	MAX HEIGHT (mm)	MIN HEIGHT (mm)		
Front Position Lamps	Min 2 Max any number Includes optional lamps	Not required on trailers for the carriage and launching of boats	White	150	O1 / O2 2100	350	a. Horizontal i. 45° Inwards ii. 5° Outwards b. Vertical i. 15° Above and below the horizontal (May be reduced to 5° if the lamps are less than 750mm above the ground)	A "E" or "e"
		Mandatory on trailers over 1600mm wide Optional on other trailers			O3 / O4 1500 or if the structure makes this impossible / impractical 2100			
Rear Position Lamps	Min 2 Max any number Includes optional lamps	Mandatory	Red	400	1500 or if the structure makes this impossible / impractical 2100	350	a. Horizontal i. 45° Inwards ii. 80° Outwards b. Vertical i. 15° above and below the horizontal (May be reduced to 5° if the lamps are less than 750mm above the ground)	R "E" or "e"
Stop Lamps	Min 2 Max any number Includes optional lamps	Mandatory	Red	400	1500 or if the structure makes this impossible / impracticable 2100	350	a. Horizontal i. 45° inwards and outwards b. Vertical i. as rear position lamps.	S1 or S2 "E" or "e"
Stop Lamps (Optional)	Min 1 Max any number	Optional	Red	If 1 is fitted: as close to trailer centre-line as practicable If 2 are fitted: no requirement	n/a	no lower than the mandatory stop lamps	Must face the rear	S1 or S2 "E" or "e"

## End-outline, Position (Side), Stop and Side Marker Lamps 22

TYPE	NUMBER	APPLICATION	COLOUR	POSITION			ANGLES OF VISIBILITY (see figure 1 & 2 of section 20)	APPROVAL MARK "E" or "e" Identity Symbol or BS Mark
				MAX DISTANCE FROM SIDE (mm)	MAX HEIGHT (mm)	MIN HEIGHT (mm)		
<b>End Outline Marker Lamp</b>	2 visible from the front and 2 visible from the rear Max any number Includes optional lamps	Mandatory on all trailers exceeding 2.10m wide	Front-White Rear - Red	As close as possible to the extreme edge and not more than 400mm from the edge		Front and Rear: as high as possible, where trailer structure exists to mount the lamps on	a. Horizontal i. 80° Outwards b. Vertical i. 5° Above the horizontal ii. 20° Below the horizontal	A or R "E" or "e"
<b>Side Marker Lamp</b>	See below	All trailers where the length exceeds 6m The length of trailers includes the drawbars) Not required on trailers for the carriage and launching of boats	Amber The rearmost marker may be red	N/A	1500 or if impracticable 2100	250	a. Horizontal i. 45° to the front and rear (Can be reduced to 30° if fitted as an optional extra) b. Vertical i. 10° Above and below the horizontal (The vertical angle below the horizontal may be reduced to 5° if the side marker lamp is fitted less than 750mm from the ground)	SM1 "E" or "e"
<b>Side Marker Lamp Spacing</b> <ul style="list-style-type: none"> <li>at least one side-marker lamp must be fitted to the middle third of the trailer</li> <li>the foremost side-marker lamp being not further than 3 m from the front</li> <li>the distance between two adjacent side-marker lamps shall not exceed 3 m, if bodywork makes it impracticable this distance may be increased to 4 m</li> <li>the distance between the rearmost side-marker lamp and the rear of the trailer shall not exceed 1 m</li> </ul>								

## End-outline, Position (Side), Stop and Side Marker Lamps 22

## Record of Revision

Revision	Date	Description of Change
1	16/04/2009	

## End-outline, Position (Side), Stop and Side Marker Lamps 22

This page intentionally left blank

## **End-outline, Position (Side), Stop and Side Marker Lamps 22**

## 23 Direction Indicators

**Application:** All Trailers

Method of Inspection	Required Standard
<p>Carry out a visual check of all direction indicators fitted to the trailer for operation, colour, number, approval marks and correct positioning.</p> <p>With optional lamps check that fitment is permitted and they do not exceed the maximum number of lamps allowed to be fitted</p>	<p><b>Directional Indicators;</b></p> <ol style="list-style-type: none"> <li>1. All lamps must be 'e' or 'E' marked and where applicable, bear the appropriate identity marking as listed in table 1</li> <li>2. They must be operational</li> <li>3. The correct number must be fitted to the trailer ( Table 1 )</li> <li>4. They must flash at a rate of between 60 and 120 times a minute</li> <li>5. All lamps must emit amber light.</li> <li>6. They must be positioned to meet               <ol style="list-style-type: none"> <li>a. the positional requirements of Table 1</li> <li>b. the angles of visibility requirements of Table 1</li> </ol> </li> </ol> <p><b>Hazard Warning Lights;</b></p> <ol style="list-style-type: none"> <li>7. The hazard warning device must operate all of the direction indicators simultaneously</li> </ol>

## Direction Indicators 23

**Table 1**

TYPE	NUMBER	APPLICATION	COLOUR	POSITION			ANGLES OF VISIBILITY (see figure 1 & 2 of section 20)	APPROVAL MARK "E" or "e" Identity Symbol or BS Mark / Notes
				MAX DISTANCE FROM SIDE (mm)	MAX HEIGHT (mm)	MIN HEIGHT (mm)		
<b>Direction Indicators &amp; Hazard Warning</b>	Trailers Rear - Two (one each side), plus 2 optional	Mandatory	Amber	400 (min separation 600 unless trailer width is less than 1300 where min separation is 400)	1500 or if impracticable 2300	350	a. Horizontal i. 80° outwards 45° inwards. b. Vertical i. < 750mm above the ground 15° above and 5° below horizontal. ii. Otherwise 15° above and below horizontal.	Rear 2a, 2b or 12  "E" or "e"

**Direction Indicators 23**

### Record of Revision

Revision	Date	Description of Change
1	16/04/2009	

This page intentionally left blank

## 24 Rear Registration Lamps

**Application:** All Trailers

Method of Inspection	Required Standard
<p>Carry out a visual check of all rear registration plate lamps fitted to the trailer for operation, colour, number and correct positioning. This includes all optional lamps. With optional lamps check that fitment is permitted and they do not exceed the maximum number of lamps allowed to be fitted</p> <p><b>Note:</b> See section 4 Rear Registration Plate Space in conjunction with position of rear registration plate lamp</p>	<p><b>Rear registration plate lamps;</b></p> <ol style="list-style-type: none"><li>1. They must be operational</li><li>2. They must be able to be switched on and off with the front and rear position lights by operating one switch</li><li>3. They must only emit white light</li><li>4. They must be positioned sufficient to illuminate the rear registration plate</li></ol>

## Record of Revision

Revision	Date	Description of Change
1	16/04/2009	

## 28 Rear Fog Lamps

**Application:** All Trailers (optional)

Method of Inspection	Required Standard
<p>Carry out a visual check of the rear fog lamps fitted to the trailer for operation, colour, number, approval marks and correct positioning. This includes optional lamps.</p> <p>With optional lamps check that fitment is permitted and they do not exceed the maximum number of lamps allowed to be fitted</p> <p><b>Note 1: Rear Fog Lamp separation</b> distance must be measured between the “illuminating surface” of each lamp.</p>	<p><b>Rear fog lamps;</b></p> <ol style="list-style-type: none"> <li>1. All lamps must be ‘e’ or ‘E’ marked and where applicable, bear the appropriate identity marking as listed in table 1</li> <li>2. They must be operational</li> <li>3. The correct number must be fitted to the trailer ( Table 1 )</li> <li>4. They must only emit a red light</li> <li>5. They must be positioned to meet               <ol style="list-style-type: none"> <li>a. the positional requirements of Table 1</li> <li>b. the angles of visibility requirements of Table 1</li> </ol> </li> <li>6. Must not be operated by a brake control</li> <li>7. Fitted so that the reflector is facing squarely to the rear</li> <li>8. An optional rear fog lamp must form a matched pair with the obligatory lamp.</li> <li>9. An optional rear fog lamp must only operate with the obligatory rear fog lamp</li> </ol>

## Rear Fog Lamps 28

**Table 1**

TYPE	NUMBER	APPLICATION	COLOUR	POSITION			ANGLES OF VISIBILITY (see figure 1 & 2 of section 20)	APPROVAL MARK "E" or "e" Identity Symbol or BS Mark / Notes
				MAX DISTANCE FROM SIDE (mm)	MAX HEIGHT (mm)	MIN HEIGHT (mm)		
Rear Fog Lamp	Min 1 Max 2	All Trailers of 1300mm in width or greater	Red	At least one must be on centre line or to offside of trailer (Min separation distance from stop lamp 100) see note 1	1000	250	a. Horizontal i. 25° inwards and outwards; if two lamps are fitted it is sufficient if one lamp (not necessarily the same lamp) – is visible throughout the range b. Vertical i. 5° above and below horizontal.	B or F "E" or "e"

## Record of Revision

Revision	Date	Description of Change
1	16/04/2009	

This page intentionally left blank

## 29 Reversing Lamps

**Application:** All Trailers

Method of Inspection	Required Standard
<p>Carry out a visual check of the reverse lamps fitted to the trailer for operation, colour, number, approval marks and correct positioning.</p> <p><b>Note:</b> If two optional lamps are fitted they may be fitted to the side, provided that they can only be switched on if the position lights are switched on. They may be switched on for slow manoeuvres in forward motion of the vehicle up to a maximum speed of 10 km/h, provided that the following conditions are fulfilled:</p> <p>(a) the devices shall be activated and deactivated manually by a separate switch;</p> <p>(b) if so activated, they may remain illuminated after reverse gear is disengaged;</p> <p>(c) they shall be automatically switched off if the forward speed of the vehicle exceeds 10 km/h, regardless of the position of the separate switch. In this case they shall remain switched off until deliberately being switched on again.</p>	<p><b>Reverse lamps;</b></p> <ol style="list-style-type: none"> <li>1. All lamps must be 'e' or 'E' marked and where applicable, bear the appropriate identity marking as listed in table 1</li> <li>2. They must be operational</li> <li>3. The correct number must be fitted to the trailer (Table 1)</li> <li>4. All reverse lamps must emit white light.</li> <li>5. They must be positioned to face the rear</li> </ol> <p><b>If two reverse lamps are fitted to the side of the trailer and used for slow manoeuvres in a forward motion</b></p> <ol style="list-style-type: none"> <li>6. The devices must be activated and deactivated manually by a separate switch</li> <li>7. They must be automatically switched off if the forward speed of the vehicle exceeds 10 km/h, regardless of the position of the separate switch. In this case they shall remain switched off until deliberately being switched on again.</li> </ol>

## Reversing Lamps 29

**Table 1**

TYPE	NUMBER	APPLICATION	COLOUR	POSITION			ANGLES OF VISIBILITY	APPROVAL MARK "E" or "e" Identity Symbol or BS Mark / Notes
				MAX DISTANCE FROM SIDE (mm)	MAX HEIGHT (mm)	MIN HEIGHT (mm)		
Reversing Lamps	Min 1 Max 2	Optional	White		1200	250	face the rear	A or R "E" or "e"

### Record of Revision

Revision	Date	Description of Change
1	16/04/2009	

This page intentionally left blank

## 36 Heating Systems

**Application:** All Trailers (if fitted)

Method of Inspection	Required Standard
<p>Ensure that the trailer presented has satisfactory evidence of compliance to the required standard</p> <p><b>A combustion heater</b></p> <p>Requires documentary evidence or an 'E' marked component plus a Installation Check</p> <p>Ensure that any heater system fitted is safe for use and is not dangerous.</p>	<p><b>Combustion Heater</b></p> <ol style="list-style-type: none"> <li>1. The trailer must be accompanied by satisfactory evidence of compliance with the required standard for "Heating Systems".</li> </ol> <p><b>Installation Check</b></p> <ol style="list-style-type: none"> <li>2. A liquid fuelled or gaseous fuelled combustion heater must be fitted in accordance with the manufacturer's instructions.</li> <li>3. There must be no likelihood of polluted air entering the accommodation / exhibition compartment.</li> <li>4. There must be no obvious fire risk associated with the heating system</li> <li>5. It must be positioned so that it is not likely to cause injury</li> <li>6. It must be positioned so exhaust gases are not likely to enter the accommodation / exhibition compartment</li> </ol>

## Heating Systems 36

## Record of Revision

Revision	Date	Description of Change
1	16/04/2009	

## 42 Lateral Protection System (Side Guards)

**Application:** All Trailers of category O3 and O4

Method of Inspection	Required Standard
<p>A trailer of category O3 or O4 is not required to be fitted with a separate lateral protection device, providing the sides of the trailer are so designed and/or equipped that by their shape and characteristics their component parts together meet the requirements in standards 2 to 18</p> <p>On a trailer fitted with extendible legs to provide additional stability during loading, unloading or other operations for which the trailer is designed, the side guard may be arranged with additional gaps where these are necessary to permit extension of the legs.</p> <p>On a trailer equipped with anchorage points for ro-ro transport, gaps shall be permitted within the side guard to accept the passage and tensioning of fixing lashings.</p> <p>An extendable trailer must comply with all the relevant requirements, when in its closed (non extended) position.</p> <p><b>Exempt Trailers :</b></p> <p>Trailers specially designed and constructed for the carriage of very long loads of indivisible length, such as timber, steel bars, etc</p> <p>Trailers designed and constructed for special purposes where it is not possible, for practical reasons, to fit such lateral protection.</p>	<p>1. Where the side of the body does not meet the requirements, a side guard device must be fitted.</p> <p><b>Requirements for both body sides and separate devices:</b></p> <p><b>Required area to be protected</b></p> <p>2. The device or body side must have its rearward edge extended to within 300mm of the tyre on the first rear axle. (see note 1 &amp; figure 1)</p> <p>3. On a draw bar trailer the front edge of the guard must be no more than 500mm to the rear of the rearmost part of the tyre on the wheel immediately forward of the guard.</p> <p>4. On a semi-trailer the front edge of the guard must be no more than 250mm to the rear of the centre line of the support legs, but in any case never more than 2.7m behind the centre of the king pin. (see figure 1)</p> <p>5. The device or body side must be within 350 mm of the body line (see note 2)</p> <p>6. The device or body side must not have a ground clearance of more than 550 mm</p> <p><b>Within the defined area the following standards must be met</b></p> <p>7. The device or body sides must be constructed of a suitable material and must be of sufficient strength (See note 3)</p>

## Lateral Protection System (Side Guards) 42

Method of Inspection	Required Standard
<p><b>Note 1:</b> The measurement is taken to a vertical plane extending from the surface of the tread closest to the guard or relevant body work.</p> <p><b>Note 2:</b> The 'Body Line' is that part of the structure of the trailer, cut or contacted by a vertical plane tangential to the outer surface of the tyres, except in the following cases:</p> <p>Where the plane does not cut the structure of the trailer, the upper edge shall be level with the surface of the load-carrying platform ,</p> <p>or</p> <p>950mm from the ground, whichever is the less.</p> <p>Where the plane cuts the structure of the trailer at a level more than 1.3m above the ground, then the upper edge of the side guard shall not be less than 950mm above the ground</p> <p><b>Note 3:</b> The manufacturer must provide satisfactory documentary evidence or a declaration that the device or body side as presented meets or has been designed to meet the following strength requirements.</p> <p>It must be capable of withstanding a horizontal static force of 1 kN applied perpendicularly to any part of its external surface by the centre of a ram the face of which is circular and flat, with a diameter of 220 mm p 10 mm,</p> <p>and</p> <p>The deflection of the guard under load must not be more than:</p> <ul style="list-style-type: none"> <li>- 30 mm over the rearmost 250 mm of the guard, and</li> <li>- 150 mm over the remainder of the guard.</li> </ul>	<p><b>8.</b> The device or body side must have a smooth or horizontally corrugated surface (see note 4)</p> <p><b>9.</b> Any external edges and corners must be rounded with a radius of at least 2.5mm</p> <p><b>10.</b> There must be no projecting brackets or bolt heads (see note 5)</p> <p><b>11.</b> The device or body side must be continuous in length (see note 6)</p> <p><b>12.</b> The device or body side must not have the rearward end more than 30mm inboard from the outermost edge of the rear tyres over at least the last 250mm of the device / body</p> <p><b><u>Where equipment is incorporated into the side guard,</u></b></p> <p><b>13.</b> The equipment must have a smooth substantially flat or horizontally corrugated outer surface (See note 4)</p> <p><b>14.</b> There must not be a gap of more than 25 mm between it and the guard or body side (see figure 2)</p> <p><b>15.</b> Where necessary the equipment must meet any required dimensional requirement as if it was part of the device.</p> <p><b>16.</b> There must be no projecting brackets or hinges</p> <p><b>17.</b> It must not have protruding bolt heads (see note 5)</p> <p><b>18.</b> Any external edges and corners must be rounded with a radius of at least 2.5mm.</p> <p><b>Additional requirements for separate devices</b></p> <p><b>19.</b> The device must be attached securely</p>

## Lateral Protection System (Side Guards) 42

Method of Inspection	Required Standard
<p><b>Note 4:</b> Any adjacent parts may overlap providing that all overlapping edges face rearwards or downwards.</p> <p><b>Note 5:</b> Dome shaped bolt heads and rivets, or other parts provided they are similarly rounded and smooth protruding to a maximum of 10mm in height are acceptable.</p> <p><b>Note 6:</b> Combinations of surfaces and rails shall be considered as a continuous side guard as long as the gaps between them are no greater than 25mm</p> <p><b>Note 7:</b> The inward measurement is taken at 90 degrees to the longitudinal plane of the trailer from the outer face of the guard; the actual face of the portion turned inwards may be between 90 and 45 degrees from the same plane towards the front of the trailer.</p>	<p><b>20.</b> The device must consist of at least one horizontal rail (see note 2 and 3)</p> <p><b>21.</b> Where more than one horizontal rail is used, the rails must be not more than 300mm apart.</p> <p><b>22.</b> For O4 trailers the horizontal rails must have a section height of at least 100 mm (figure 3)</p> <p><b>23.</b> For O3 trailers the horizontal rails must have a section height of at least 50 mm (figure 3)</p> <p><b>24.</b> It must have a forward facing edge of at least 100 mm</p> <p><b>25.</b> The side guard must be no more than 120mm inboard from the outermost plane of the trailer</p> <p><b>26.</b> It must not increase the overall width of the trailer</p> <p><b>27.</b> The device must not be used for the attachment of air or hydraulic brake pipes</p> <p><b>28.</b> Where the forward edge lies in open space then the following requirements must be met :-</p> <ul style="list-style-type: none"> <li><b>a.</b> There must be a continuous vertical member extending over the whole height of the device</li> <li><b>b.</b> For O3 trailers, the outer and forward faces must measure at least 50 mm rearward and be turned 100 mm inwards. (see note 7 and figure 3)</li> <li><b>c.</b> For O4 trailer, the outer and forward faces must measure at least 100 mm rearward and be turned 100 mm inwards. (see note 7 and figure 3)</li> </ul>

## Lateral Protection System (Side Guards) 42

Figure 1

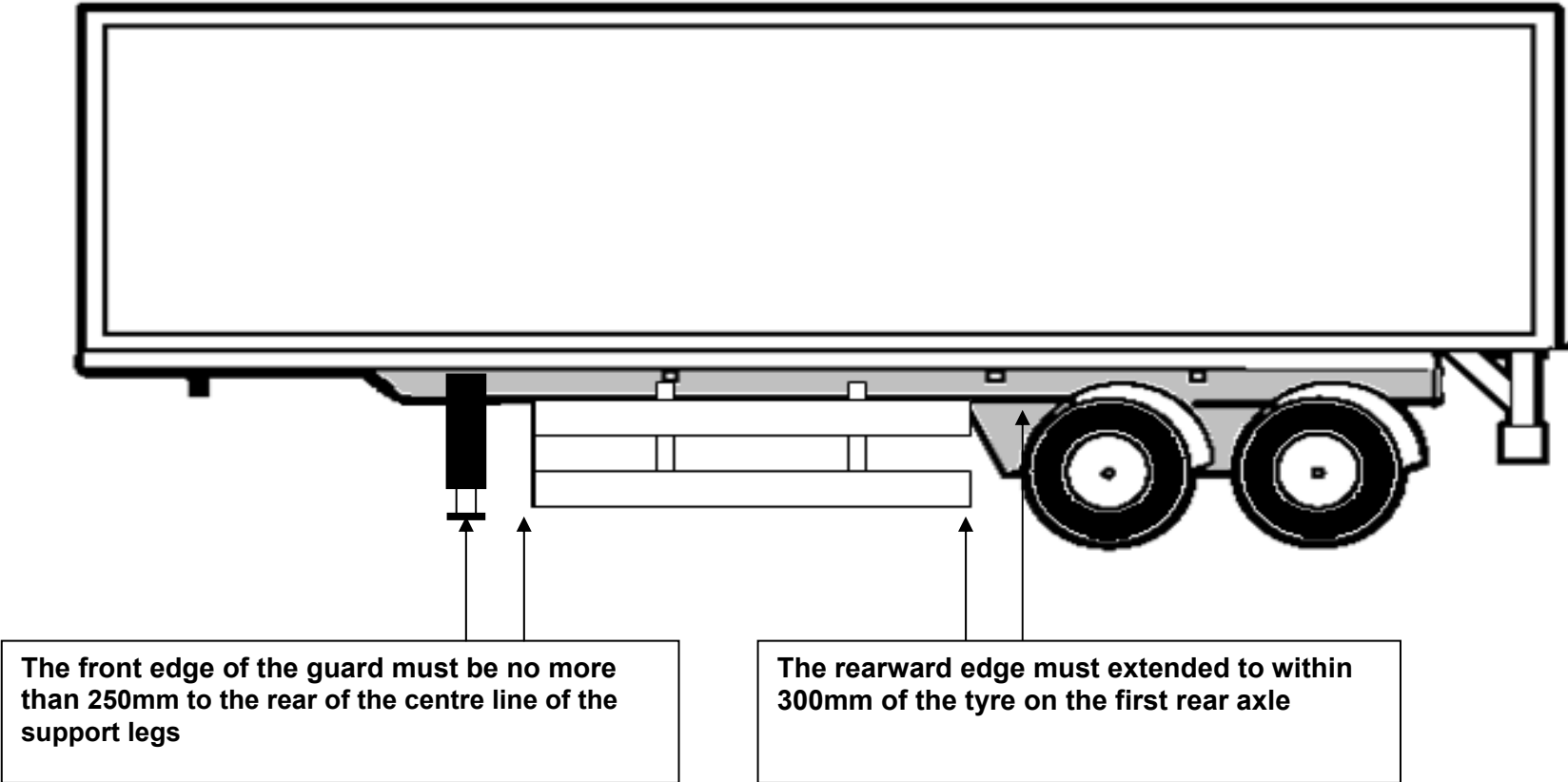

# Lateral Protection System (Side Guards) 42

Figure 2

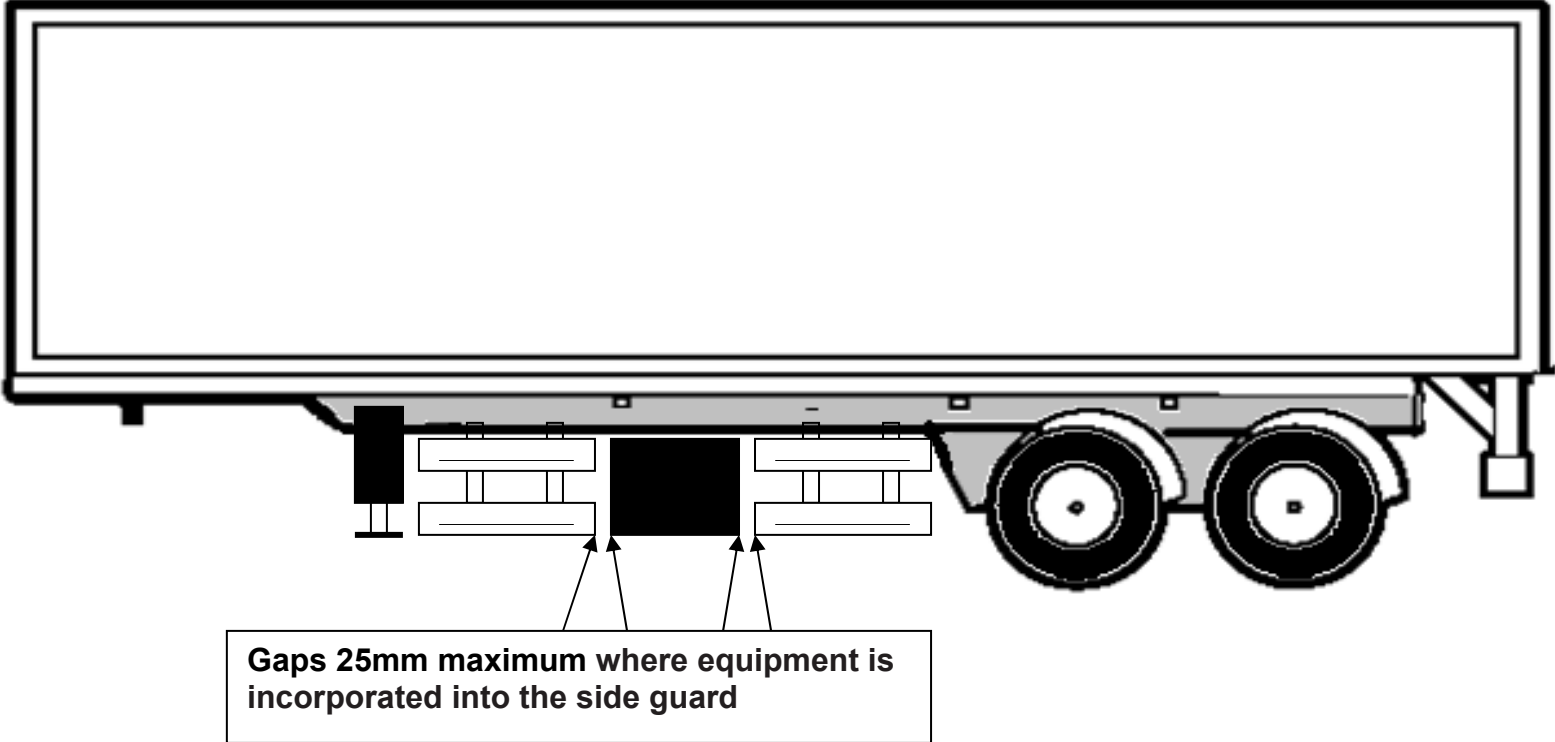

**Lateral Protection System (Side Guards) 42**

Figure 3

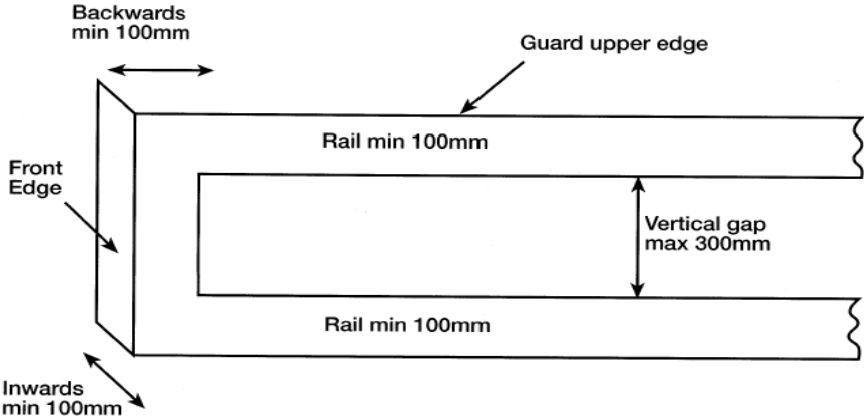
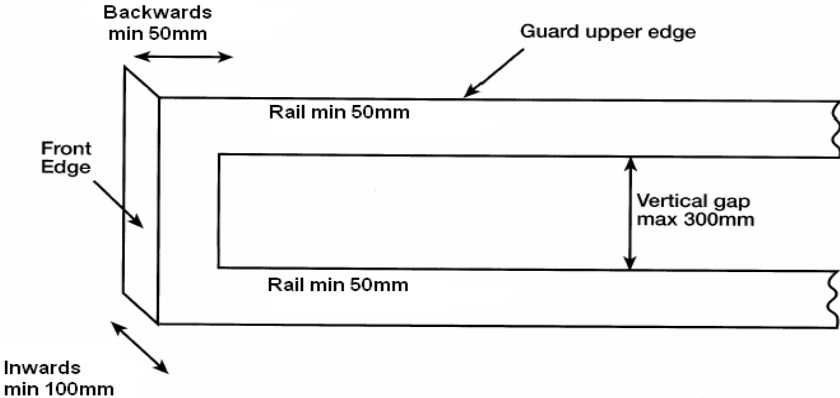

# Lateral Protection System (Side Guards) 42

## Record of Revision

Revision	Date	Description of Change
1	16/04/2009	

## Lateral Protection System (Side Guards) 42

This page intentionally left blank

## 43 Spray Suppression

**Application:** All Trailers of category O3 and O4

Method of Inspection	Required Standard
<p>All road wheels must be fitted with Spray Suppression devices.</p> <p><b>Mudguard</b> Is a device to prevent as far as practical mud or water being thrown from a tyre. They may be formed using parts of the body or they may be an entirely separate unit.</p> <p><b>Outer Valances</b> Are usually strips of material that are fitted longitudinally across a wheel space attached at one end to a rain flap to form an outer wheel arch lip, a vertical downward face that closes off what would be an open area.</p> <p><b>Rain flaps</b> Can be a flexible extension to a wing or it may form the rear most vertical face of a wing in conjunction with the body, in this latter case it must be treated as a wing and be securely fixed to prevent excessive movement.</p> <p><b>Lifting axles</b> Where a trailer is fitted with one or more lifting axles, the spray-suppression system must cover all the wheels when the axle is lowered and the remaining wheels which are in contact with the ground when the axle is raised</p>	<p><b>Component Check</b></p> <ol style="list-style-type: none"> <li>1. Every road wheel must be fitted with a Spray Suppression system.</li> <li>2. All Spray Suppression material must be of an approved type. (see note 1 and 2)</li> <li>3. All components must be secured so that they perform their function.</li> </ol> <p><b>Installation Check</b></p> <p><b>Mudguards (fitted in combination with energy absorption materials).</b></p> <ol style="list-style-type: none"> <li>4. must fully cover the zone immediately above, ahead and behind any part of the tyre or tyres see Figure 1 2 and 3</li> <li>5. in the case of non steered wheels must have the lower front edge no more than 20 degrees above the horizontal line of the axle ( <b>A</b> on figure 1)</li> <li>6. in the case of steered wheels must have the lower front edge no more than 30 degrees above the horizontal line of the axle ( <b>A</b> on figure 1)</li> <li>7. must have the lower-rear edge no more than 100mm above the horizontal line of the axle ( <b>C</b> on figure 1)</li> </ol>

## Spray Suppression 43

Method of Inspection	Required Standard
<p><b>Self-tracking axles</b> Where a trailer is fitted with a self-tracking axle, the spray-suppression system must satisfy the conditions applicable to non-steered wheels if mounted on the pivoting part. If not mounted on that part, it must satisfy the conditions that are applicable to steered wheels.</p> <p><b>Note 1:</b> All spray suppression materials must be either e marked or be accompanied by an e marked sample of the material to permit the examiner to make a comparison.</p> <p><b>Note 2:</b> 'Spray-suppression device' means part of the spray-suppression system, which may comprise:</p> <p>Air/water separator: This is a component forming part of the valance and/or of the rain flap through which air can pass whilst reducing pulverized water emissions.</p> <p><b>or</b></p> <p>Energy absorber: This is a component forming part of the mudguard and/or valance and/ or rain flap which absorbs the energy of water spray, thus reducing pulverized water spray.</p> <p><b>Note 3:</b> Where rope hooks are fitted the outer valance may meet the requirements of figure 6 as an alternative.</p>	<p>8. must have Spray Suppression material fitted to the front face of the rear of the guard facing the tyre tread, complying with the dimensional requirements of figure 1. and 3</p> <p>9. that consist of several components must have no gaps between or within individual parts when assembled that will permit the exit of spray when the trailer is in motion.</p> <p><b>Additional standard where Separate Mudguards are fitted (in combination with air/water separation to multiple axle configurations).</b></p> <p>10. where the distance between the tyres on adjacent axles does not exceed 300 mm the mudguards must also conform to the model shown in Figure 7.</p> <p><b>Alternative Standards from standards 4-10 where the body forms the mudguards (and energy absorption systems are fitted).</b></p> <p>11. must cover the zone above the tyre or tyres from the front edge of the tyre to the rain flap located behind the wheel see figure 5</p> <p>12. must have their inner faces made from or be fitted with a spray suppression material.</p> <p><b>Outer Valances (with energy absorption Spray Suppression systems installed).</b></p> <p>13. fitted to steered and self-steered wheels must have its vertical face within 100mm of the tyre wall (<b>D</b> on figure 2) see note 3</p> <p>14. fitted to non -steered wheels must have its vertical face within 75 mm of the tyre wall (<b>D</b> on figure 2)see note 3</p>

## Spray Suppression 43

Method of Inspection	Required Standard
	<p><b>15.</b> must have a depth of at least 45mm, at all points behind a vertical line passing through the centre of the wheel see Figure 2</p> <p><b>16.</b> fitted to steered wheels must have the lower edge within 1.5 x tyre radius at points A,B and C as shown in Figure 4</p> <p><b>17.</b> fitted to non - steered wheels must have the lower edge within 1.25 x tyre radius at points A,B and C as in Figure 4</p> <p><b>18.</b> must have no openings in them or between them and other parts of the mudguard enabling spray to emerge.</p> <p><b>Alternative standards (to 13 -18 ) for Outer Valances (where the body forms the mudguard over non steered or self steering wheels and an energy absorption spray suppression system is installed).</b></p> <p><b>19.</b> must be located above each wheel of multiple axles where a rain flap is fitted between each wheel. See figure 5</p> <p><b>20.</b> must have the entire inner surface fitted with an energy-absorption spray-suppression material.</p> <p><b>21.</b> must be a minimum of 100mm high</p> <p><b>22.</b> must have no openings in them or between the outer valance and the inner part of the mud guard enabling spray to emerge.</p> <p><b>23.</b> must be continuous where rain flaps are not fitted behind each wheel, they must extend between the outer edge of the rain flap and a vertical plane passing through the front edge of the tyre. See figure 5</p>

## Spray Suppression 43

Method of Inspection	Required Standard
	<p><b>Outer Valances (with air/water separation Spray Suppression systems installed).</b></p> <ul style="list-style-type: none"> <li><b>24.</b> must have air/water separator spray-suppression devices fitted to the lower edges.</li> <li><b>25.</b> must have a depth of at least 45mm, at all points behind a vertical line passing through the centre of the wheel</li> <li><b>26.</b> fitted to steered wheels must have its lowest edge within 1.05 x tyre radius see figure 7</li> <li><b>27.</b> fitted to non-steered wheels must have its lowest edge within 1 x tyre radius see figure 7</li> <li><b>28.</b> must have no openings in them or between them and the mudguard enabling spray to emerge</li> </ul> <p><b>Rain Flaps : (where energy absorption Spray Suppression systems are installed)</b></p> <ul style="list-style-type: none"> <li><b>29.</b> must be at least equal to the full width of the tyre/s</li> <li><b>30.</b> must be vertical</li> <li><b>31.</b> must have the lower edge no more than 200 mm above the ground</li> <li><b>32.</b> must be no more than 300 mm from a vertical plane passing through the rearmost edge of the tyre</li> <li><b>33.</b> must have no openings between the rain flap and the lower edge of the wheel guard enabling spray to emerge.</li> <li><b>34.</b> must have the whole face made of spray suppression material.</li> </ul>

## Spray Suppression 43

Method of Inspection	Required Standard
	<p><b>35.</b> must be fitted to the rearmost axle of multiple axles where distance between the tyres on adjacent axles is less than 250 mm,</p> <p><b>36.</b> must be fitted behind each wheel of multiple axles when the distance between the tyres on adjacent axles is 250 mm or greater.</p> <p><b>Rain Flaps : (where the body forms the mudguard and energy absorption Spray Suppression systems are installed)</b></p> <p><b>37.</b> must extend to the lower part of the mud guard and comply with standards 29 to 36</p> <p><b>Rain Flaps (where air/water Separation Systems are installed)</b></p> <p><b>38.</b> must be at least equal to the full width of the tyre/s</p> <p><b>39.</b> must be vertical</p> <p><b>40.</b> must have no openings between the rain flap and the lower edge of the wheel guard enabling spray to emerge.</p> <p><b>41.</b> must be fitted to the rearmost axle of multiple axles where distance between the tyres on adjacent axles is less than 250 mm.</p> <p><b>42.</b> must be fitted behind each wheel of multiple axles when the distance between the tyres on adjacent axles is 250 mm or greater.</p> <p><b>43.</b> must not be more than 200 mm from the rearmost edge of the tyre, measured horizontally.</p> <p><b>44.</b> must be at least 100 mm deep.</p>

## Spray Suppression 43

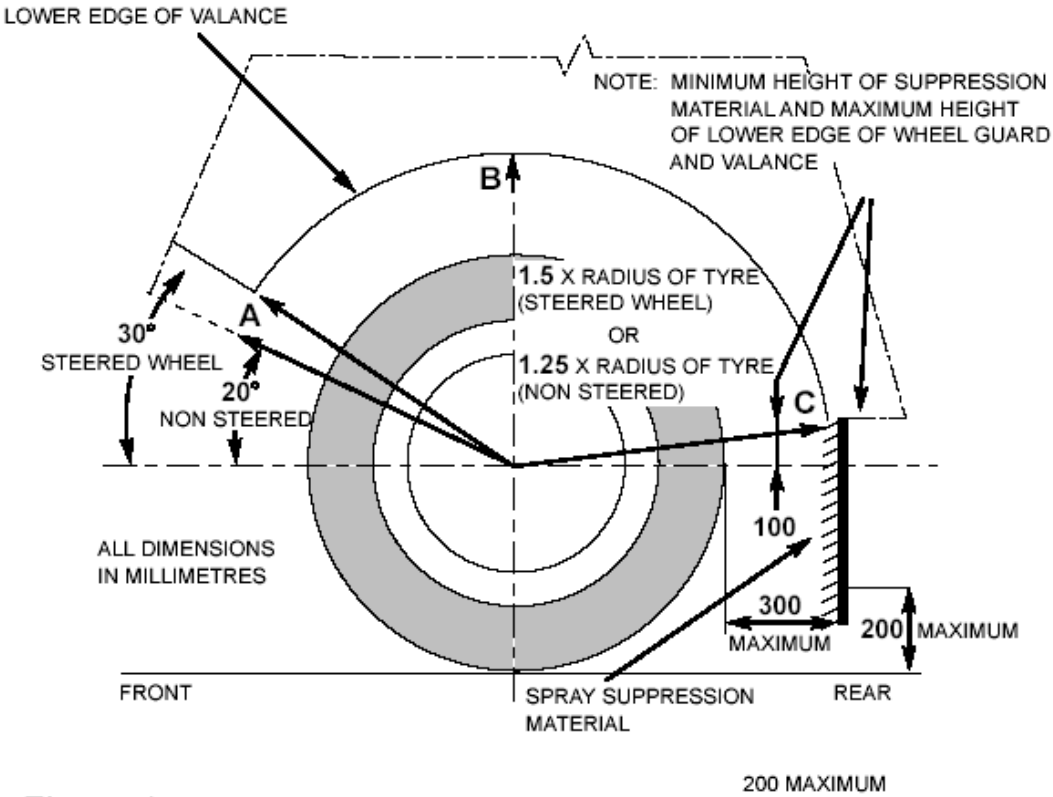

Figure 1

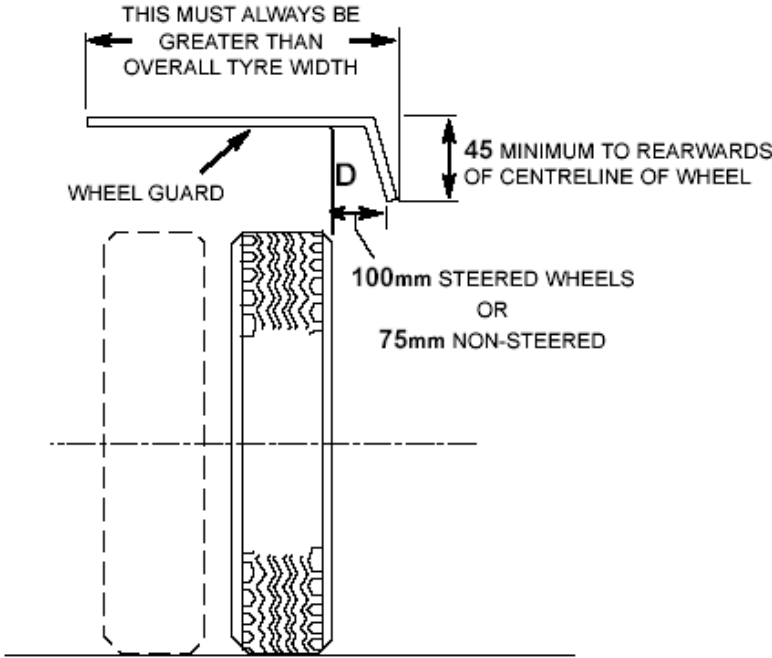
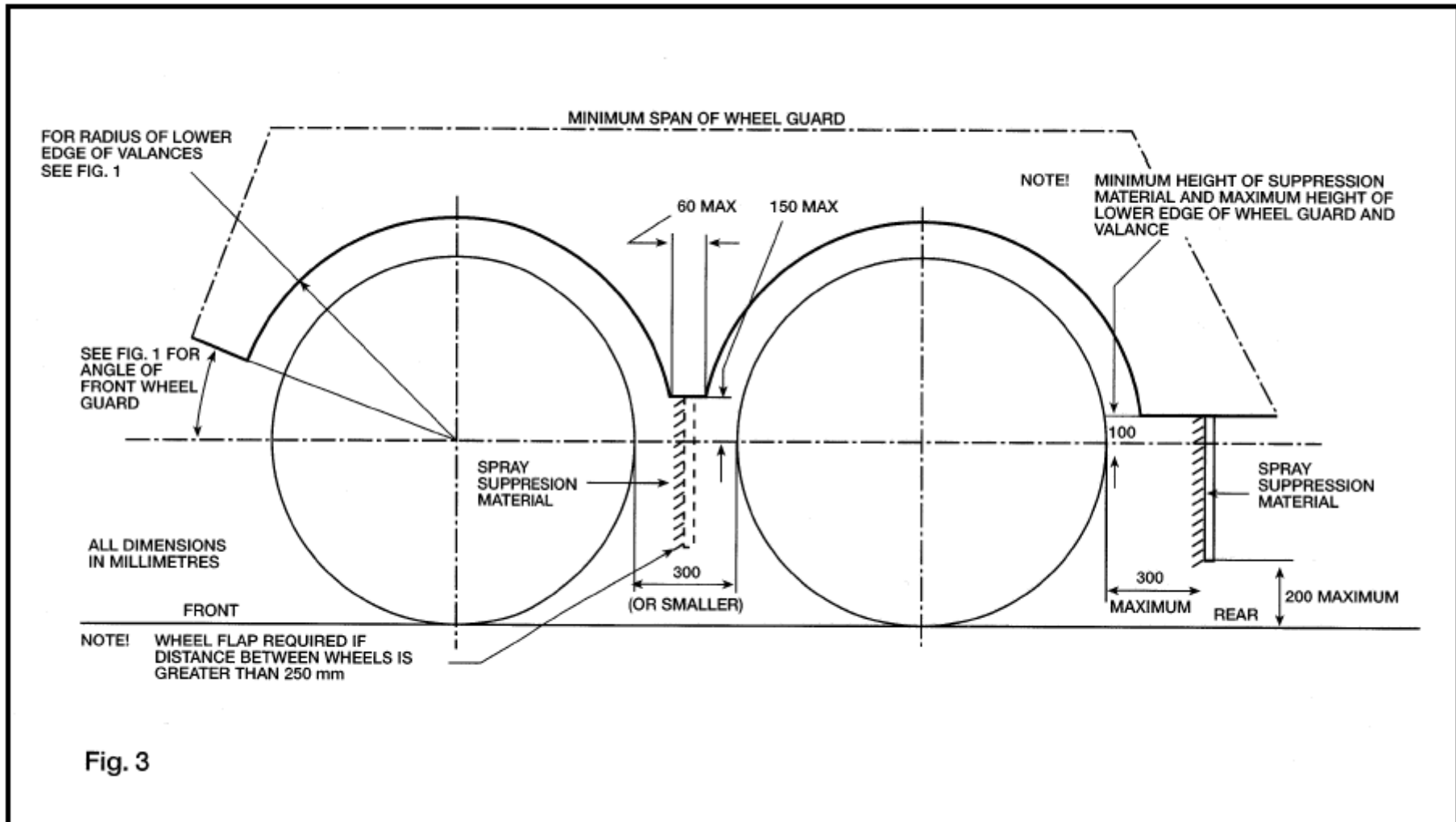

Figure 2

# Spray Suppression 43



## Spray Suppression 43

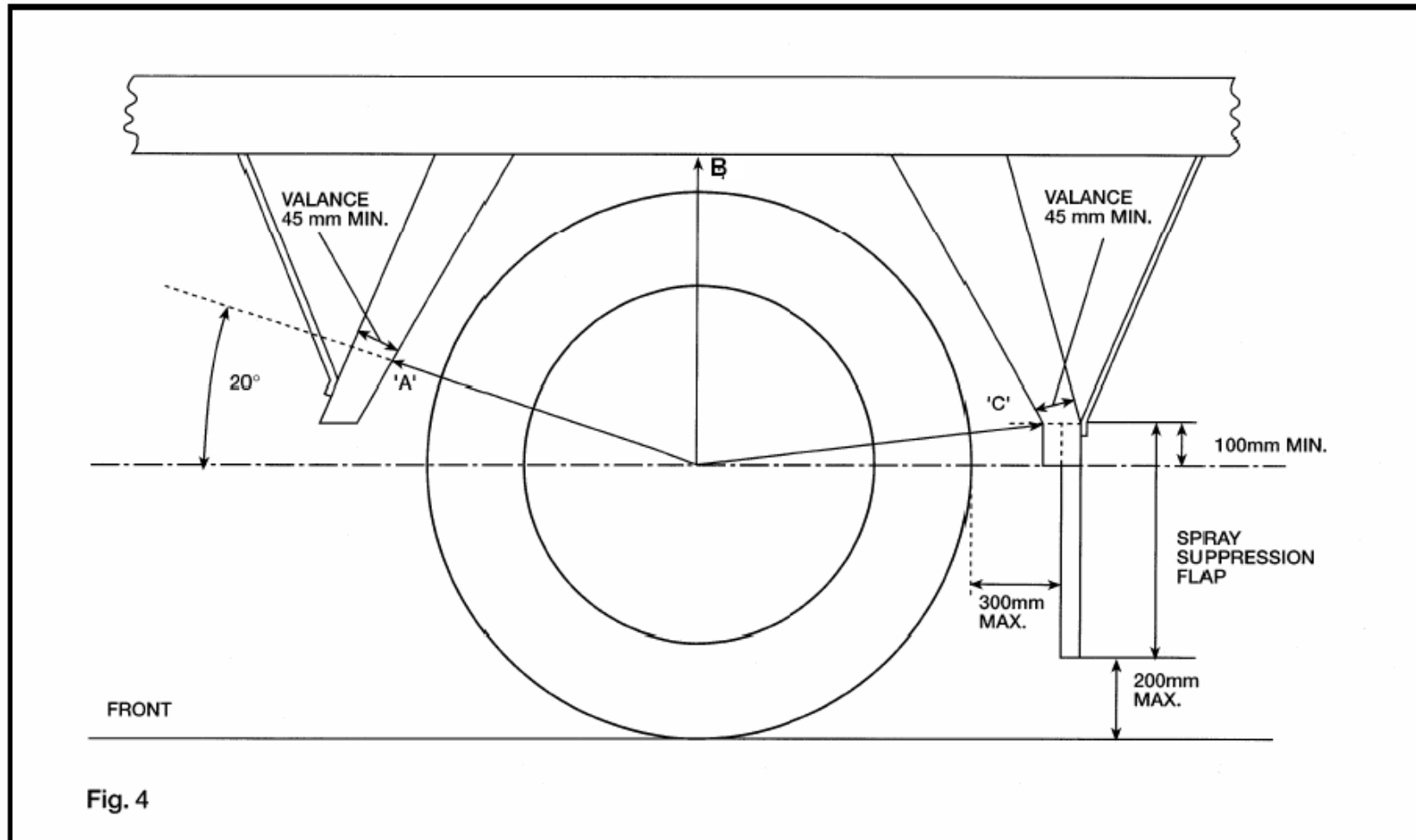

Fig. 4

The lower edge of the outer valance shall not exceed 1.5 x tyre radius on steerable wheels or 1.25 x tyre radius on non-steerable wheels at points A,B and C.

## Spray Suppression 43

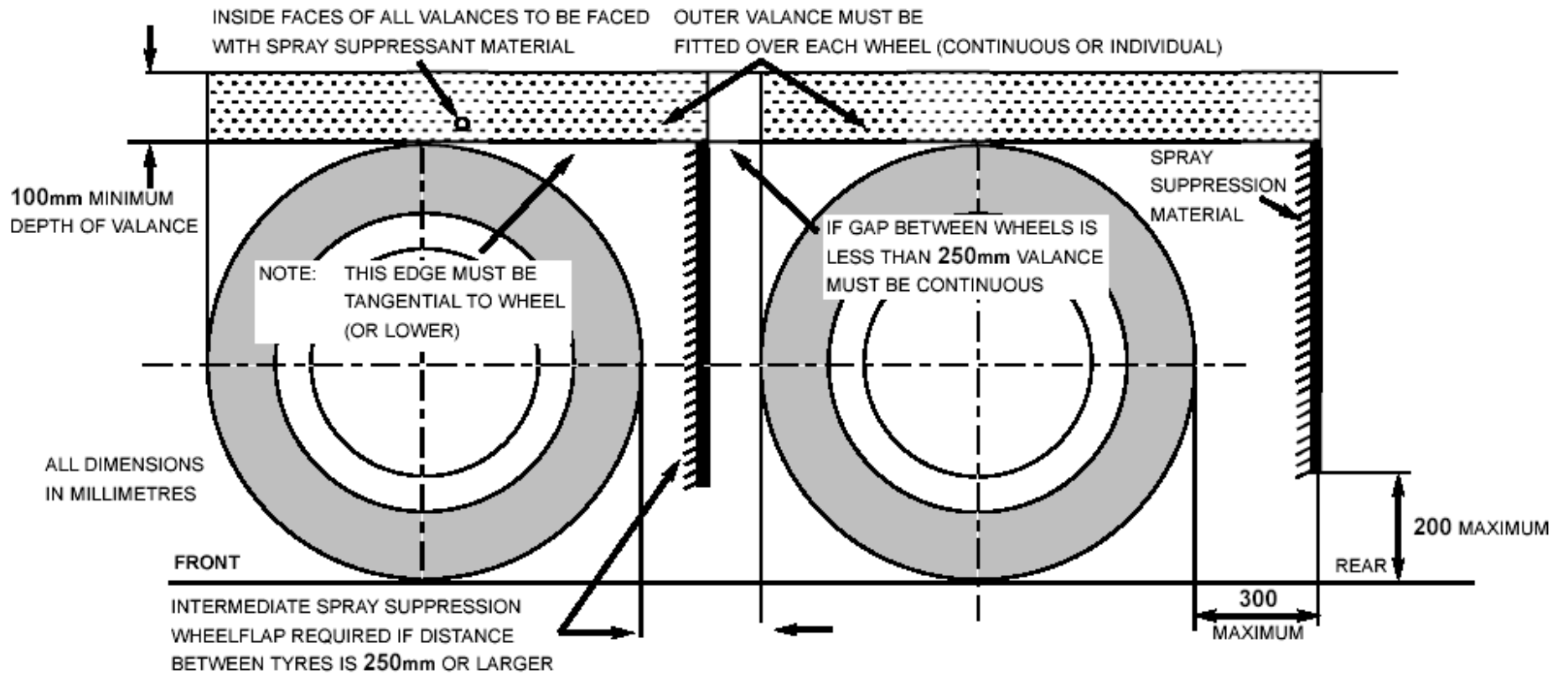
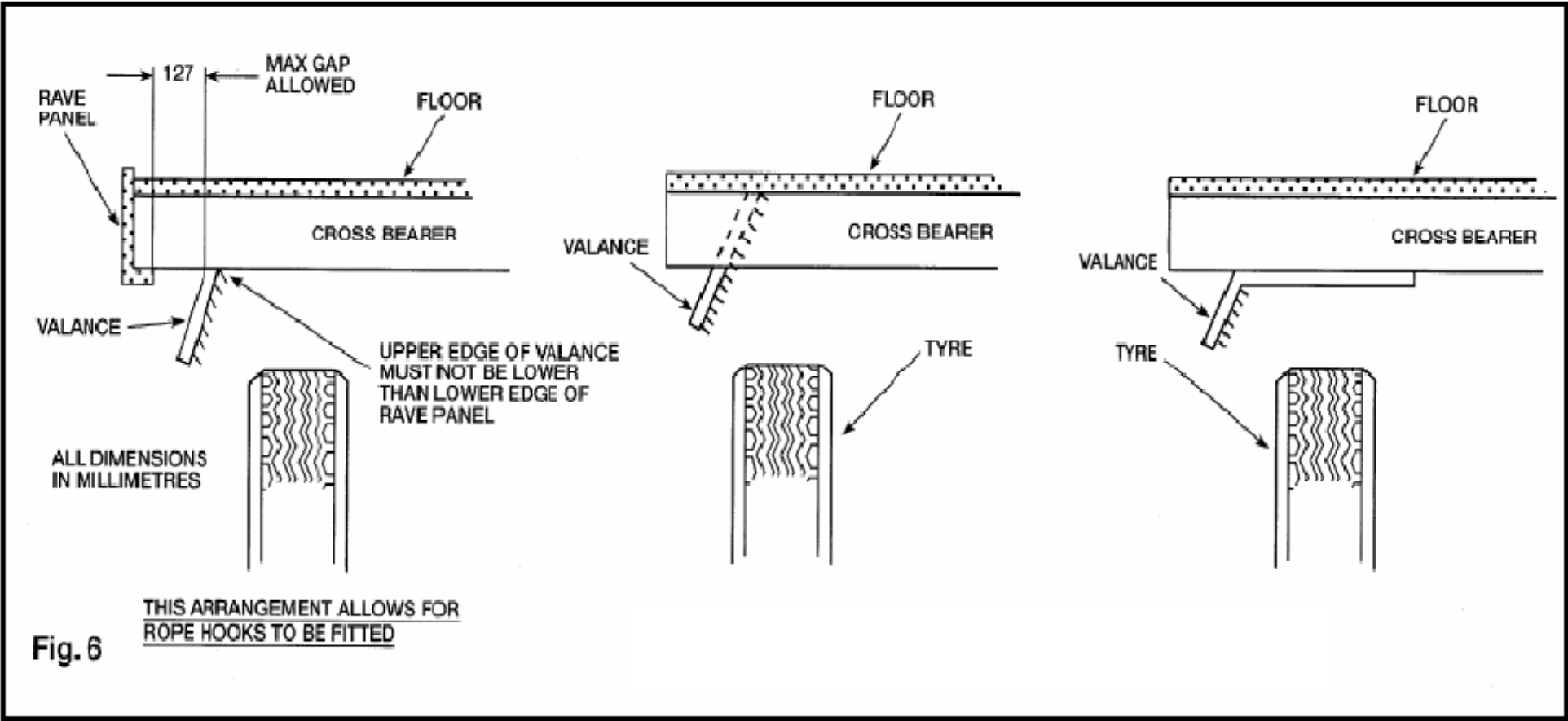

Figure 5

## Spray Suppression 43



# Spray Suppression 43

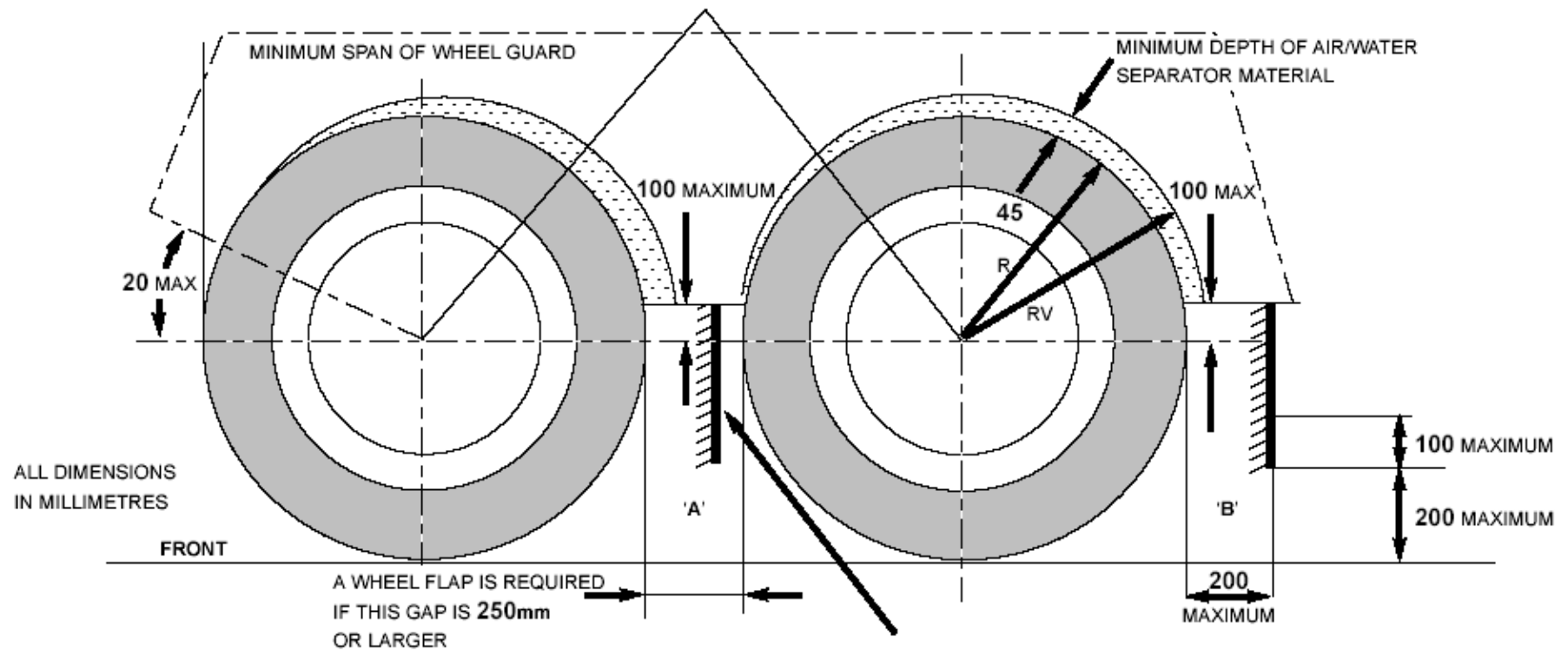

Figure 7

where R = is the radius of tyre fitted to the trailer;  
 RV = the radial distance from the lowest edge of the outer valance to the centre of the wheel.

$RV \leq 1.05$  on steered wheels  
 $RV \leq 1.00$  on non-steered wheels

## Spray Suppression 43

### Record of Revision

Revision	Date	Description of Change
1	16/04/2009	

# 45 Safety Glass

**Application:** All Trailers



Method of Inspection	Required Standard
<p>Check that all windows are securely attached to the trailer and are constructed from approved materials.</p> <p><b>Note 1:</b> "Safety Glazing" made from glass must be so constructed or treated that if fractured it does not fly into fragments likely to cause severe cuts. Each piece of glass must display the following relevant permanent marking applied by the glass manufacturer.</p> <p>ECE Regulation 43      </p> <p><b>Note 2:</b> "Safety Glazing" made from plastic means material which is so constructed or treated that if fractured it does not fly into fragments likely to cause severe cuts. "Safety glazing" made from plastic must have an "e" mark applied by the material manufacturer.</p>	<ol style="list-style-type: none"><li>1. All windows / partitions where fitted must be securely attached to the trailer.</li><li>2. All windows / partitions must be made of safety glass to a recognised standard or from safety glazing (not applicable to armoured trailers).</li><li>3. All windows made of safety glass / safety glazing must bear the relevant approval marking applied by the glazing manufacturer (not applicable to armoured trailers).</li></ol>

# Record of Revision

Revision	Date	Description of Change
1	16/04/2009	

# 46 Tyres

**Application:** All Trailers

Method of Inspection	Required Standard
<p>Check each tyre for correct fitment, structure and that it has the correct markings to confirm compliance with the required standards. Where it is not possible to check markings, a declaration will be required from the applicant.</p> <p><b>Note 1:</b> Structure means the technical characteristics of the tyres carcass, such as diagonal or bias ply, bias belted, Radial, reinforced.</p> <p><b>Note 2:</b> Type of tyre means tyres which do not differ in such essential respects as Manufacturer's name or trade mark, tyre size designation, category of use (special, snow tyre etc), speed category, load capacity index and tyre cross section.</p> <p><b>Note 3:</b> Tyres with no category of use designation (special, snow tyre etc), will be deemed to be Normal Use Tyres</p> <p><b>Annex 1</b></p> <div style="display: flex; justify-content: space-around;"> <div style="text-align: center;"> <p>EC Type Approval Mark</p> <p>Box should be a minimum of 12mm x 8mm</p>  <p>Letters and numbers, minimum of 4mm high</p> </div> <div style="text-align: center;"> <p>UNECE Type Approval Mark</p> <p>Circle with a minimum diameter of 12mm</p>  <p>Number 4mm high and serial number alongside</p> </div> </div>	<ol style="list-style-type: none"> <li>1. Each tyre fitted to the trailer, including any spare or temporary use spare, must have the correct approval marks. (Annex 1)</li> <li>2. The tyre must also be marked with the following information :- Manufacturer's name or trade mark, tyre size designation, category of use (special, snow tyre etc), speed category, load capacity index and tyre cross section.</li> <li>3. Each of the tyres fitted to a trailer, excluding any temporary use spare, must have the same structure. (see note 1)</li> <li>4. Each of the tyres fitted to any one axle must be of the same type. (see note 2)</li> <li>5. Each tyre must have the correct load indices, speed ratings and use markings as appropriate, taking into account the trailer to which it is fitted, and the type of use for the trailer will be subject to. (See note 1,2 and 3 and tables 1&amp; 2)</li> <li>6. Each wheel and tyre must have sufficient room to revolve so as to ensure that it is unlikely to foul on any part, taking into consideration the suspension and steering constraints provided by the manufacturer</li> <li>7. Tyres must be fitted in accordance with the manufacturer's instructions as indicated on the side wall of the tyre.</li> </ol>

## Tyres 46

Method of Inspection	Required Standard
	<p><b>8.</b> O1 and O2 trailers; the grooves of the tread pattern must be at least 1.6mm in depth throughout a continuous band comprising of the centre <math>\frac{3}{4}</math> of the original breadth of the tread pattern. (excluding wear indicators)</p> <p><b>9.</b> O3 and O4 trailers; the grooves of the tread pattern must be at least 1mm in depth throughout a continuous band comprising of at least <math>\frac{3}{4}</math> of the original breadth of the tread pattern (excluding wear indicators)</p> <p><b>10.</b> O1 and O2 trailers fitted with passenger car tyres in single formation, the maximum load rating of every tyre must be at least equal to 0.45 times the maximum mass for the most heavily loaded axle, as declared by the manufacturer of the trailer. For tyres in dual (twin) formation this factor is 0.24.</p>

The Minimum required speed ratings are:

**Table 1**

Class of Vehicle	Permitted Speed MPH	Minimum Speed Symbol Required
Trailers	60	J

**Table 2**

Load Index	Max KG	Load Index	Max KG	Load Index	Max KG	Load Index	Max KG	Load Index	Max KG	Load Index	Max KG
0	45	35	121	70	335	105	925	140	2 500	168	5 600
1	46,2	36	125	71	345	106	950	141	2 575	169	5 800
2	47,5	37	128	72	355	107	975	142	2 650	170	6 000
3	48,7	38	132	73	365	108	1 000	143	2 725	171	6 150
4	50	39	136	74	375	109	1 030	144	2 800	172	6 300
5	51,5	40	140	75	387	110	1 060	145	2 900	173	6 500
6	53	41	145	76	400	111	1 090	146	3 000	174	6 700
7	54,5	42	150	77	412	112	1 120	147	3 075	175	6 900
8	56	43	155	78	425	113	1 150	148	3 150	176	7 100
9	58	44	160	79	437	114	1 180	149	3 250	177	7 300
10	60	45	165	80	450	115	1 215	150	3 350	178	7 500
11	61,5	46	170	81	462	116	1 250	151	3 450	179	7 750
12	63	47	175	82	475	117	1 285	152	3 550	180	8 000
13	65	48	180	83	487	118	1 320	153	3 650	181	8 250
14	67	49	185	84	500	119	1 360	154	3 750	182	8 500
15	69	50	190	85	515	120	1 400	155	3 875	183	8 750
16	71	51	195	86	530	121	1 450	156	4 000	184	9 000
17	73	52	200	87	545	122	1 500	157	4 125	185	9 250
18	75	53	206	88	560	123	1 550	158	4 250	186	9 500
19	77,5	54	212	89	580	124	1 600	159	4 375	187	9 750
20	80	55	218	90	600	125	1 650	160	4 500	188	10 000
21	82,5	56	224	91	615	126	1 700	161	4 625	189	10 300
22	85	57	230	92	630	127	1 750	162	4 750	190	10 600
23	87,5	58	236	93	650	128	1 800	163	4 875	191	10 900
24	90	59	240	94	670	129	1 850	164	5 000	192	11 200
25	92,5	60	250	95	690	130	1 900	165	5 150	193	11 500
26	95	61	257	96	710	131	1 950	160	4 500	194	11 800
27	97,5	62	265	97	730	132	2 000	161	4 625	195	12 150
28	100	63	272	98	750	133	2 060	162	4 750	196	12 500
29	103	64	280	99	775	134	2 120	163	4 875	197	12 850
30	106	65	290	100	800	135	2 180	164	5 000	198	13 200
31	109	66	300	101	825	136	2 240	165	5 150	199	13 600
32	112	67	307	102	850	137	2 300	160	4 500	200	14 000
33	115	68	315	103	875	138	2 360	166	5 300		
34	118	69	325	104	900	139	2 430	167	5 450		

**Note:** This indicates the maximum load each tyre can carry.

# Tyres 46

Table 3

**LOAD CAPACITY INDEX TABLE  
EXTRACT FROM ECE REG 54: "LOAD INDEX" TABLE AMENDED TO SHOW AXLE  
LOADS**

LOAD INDEX	SINGLE Kg	DUAL Kg	LOAD INDEX	SINGLE Kg	DUAL Kg	LOAD INDEX	SINGLE Kg	DUAL Kg
70	670	1340	110	2120	4240	150	6700	13400
71	690	1380	111	2180	4360	151	6900	13800
72	710	1420	112	2240	4480	152	7100	14200
73	730	1460	113	2300	4600	153	7300	14600
74	750	1500	114	2360	4720	154	7500	15000
75	774	1548	115	2430	4860	155	7750	15500
76	800	1600	116	2500	5000	156	8000	16000
77	824	1648	117	2570	5140	157	8250	16500
78	850	1700	118	2640	5280	158	8500	17000
79	874	1748	119	2720	5440	159	8750	17500
80	900	1800	120	2800	5600	160	9000	18000
81	924	1848	121	2900	5800	161	9250	18500
82	950	1900	122	3000	6000	162	9500	19000
83	974	1948	123	3100	6200	163	9750	19500
84	1000	2000	124	3200	6400	164	10000	20000
85	1030	2060	125	3300	6600	165	10300	20600
86	1060	2120	126	3400	6800	166	10600	21200
87	1090	2180	127	3500	7000	167	10900	21800
88	1120	2240	128	3600	7200	168	11200	22400
89	1160	2320	129	3700	7400	169	11600	23200
90	1200	2400	130	3800	7600	170	12000	24000
91	1230	2460	131	3900	7800	171	12300	24600
92	1260	2520	132	4000	8000	172	12600	25200
93	1300	2600	133	4120	8240	173	13000	26000
94	1340	2680	134	4240	8480	174	13400	26800
95	1380	2760	135	4360	8720	175	13800	27600
96	1420	2840	136	4480	8960	176	14200	28400
97	1460	2920	137	4600	9200	177	14600	29200
98	1500	3000	138	4720	9440	178	15000	30000
99	1550	3100	139	4860	9720	179	15500	31000
100	1600	3200	140	5000	10000			
101	1650	3300	141	5150	10300			
102	1700	3400	142	5300	10600			
103	1750	3500	143	5450	10900			
104	1800	3600	144	5600	11200			
105	1850	3700	145	5800	11600			
106	1900	3800	146	6000	12000			
107	1950	3900	147	6150	12300			
108	2000	4000	148	6300	12600			
109	2060	4120	149	6500	13000			

## Record of Revision

Revision	Date	Description of Change
1	16/04/2009	

This page intentionally left blank

## 48 Masses and Dimensions

**Application:** All Trailers

Method of Inspection	Required Standard																		
<p>This inspection is to ensure that the trailer as presented has satisfactory evidence of compliance to the required standard and has not been subject to modifications that may invalidate any approval held</p> <p>Trailers complying with the Road Vehicles (Authorisation of Special Types)(General) Order 2003 or the Motor Vehicles (Authorisation of Special Types) Order (Northern Ireland) 1997 are exempt from any of the standards which they are unable to comply with due to their special purpose.</p> <p><b>Note 1:</b> The following trailers are exempt the requirements</p> <p>A trailer for abnormal indivisible loads of exceptional length;</p> <p>A trailer being a drying or mixing plant designed for the production of asphalt or of bituminous or tar macadam and used mainly for the construction, repair or maintenance of roads;</p> <p>A road planing machine;</p> <p><b>Note 2:</b> In the case of a semi-trailer which is designed to carry at least 2 other wheeled vehicles, for the distance mentioned in Table I (12000mm), shall be substituted 12500mm <b>and</b> (2040mm), shall be substituted 4190mm</p>	<p><b>Dimensions:</b></p> <p>1. The trailer must not exceed the maximum authorised dimensions shown in the table below. (See notes 1 &amp; 2)</p> <table border="1" data-bbox="1070 584 2112 852"> <thead> <tr> <th>Category</th> <th>WIDTH See Annex 1</th> <th>LENGTH See Annex 1</th> </tr> </thead> <tbody> <tr> <td>O1</td> <td>2300mm</td> <td>7000mm</td> </tr> <tr> <td>O2</td> <td>2300mm(A)</td> <td>7000mm(B)</td> </tr> <tr> <td>O3</td> <td>2550mm (C)</td> <td>12000mm (D)</td> </tr> <tr> <td>O4</td> <td>2550mm (C)</td> <td>12000mm (D)</td> </tr> <tr> <td>Semi-trailer</td> <td></td> <td>2040mm (E)</td> </tr> </tbody> </table> <p>(A) Width of 2550mm is permitted, but only if the trailer is to be towed solely by vehicles with GVW exceeding 3500kg, in line with Regulation 8 of the Road Vehicles (Construction and Use) Regulations 1986. A trailer this size must be accompanied to test by a suitable towing vehicle, otherwise a refusal to test will be issued.</p> <p>(B) Length of 12000mm is permitted, under condition described in (A), but in addition the trailer must have at least 4 wheels. (at least 2 axles)</p> <p>(C) 2600mm for the superstructure of trailers designed for transport of goods under controlled temperatures.</p> <p>(D) measured from the fifth-wheel king pin to the rear of the semi-trailer</p> <p>(E) measured from the fifth-wheel king pin to the forward-most point of the semi-trailer</p>	Category	WIDTH See Annex 1	LENGTH See Annex 1	O1	2300mm	7000mm	O2	2300mm(A)	7000mm(B)	O3	2550mm (C)	12000mm (D)	O4	2550mm (C)	12000mm (D)	Semi-trailer		2040mm (E)
Category	WIDTH See Annex 1	LENGTH See Annex 1																	
O1	2300mm	7000mm																	
O2	2300mm(A)	7000mm(B)																	
O3	2550mm (C)	12000mm (D)																	
O4	2550mm (C)	12000mm (D)																	
Semi-trailer		2040mm (E)																	

## Masses and Dimensions 48

Method of Inspection	Required Standard
<p>A Plating examination under the Goods Vehicle (Plating and Testing) Regulations 1988 must be carried out during the IVA examination, and a Plating certificate issued after the IVA certificate is issued. This does not apply in the case of trailers exempted from Plating, and trailers intended to be based in Northern Ireland. In these cases the Statutory Plate prescribed in Section 18 of this manual must have 2 columns, one for maximum GB/NI weights and one for maximum technically permissible weights (if different).</p> <p><b>Note 3:</b> In most cases a trailer submitted for test will be unladen and will be obviously well within the permissible weights set out in Annex 1 to section 18. However, if it seems likely that the trailer or an axle (as presented) exceeds any of these weights, the trailer should be weighed or a weight ticket requested.</p> <p><b>Note 4:</b> Satisfactory documentary evidence or a declaration from the trailer assembler should be provided, stating that the trailer complies with this standard</p> <p><b>Note 5:</b> Check that the trailer combination is able to manoeuvre a complete circular trajectory of 360 degrees inside an area defined by two concentric circles, without any of the vehicles outermost points projecting outside the circumferences of the circles (See figure 1). This must be completed on both steering locks</p> <p>The outer circle having a radius of 12.50 metres The inner circle having a radius of 5.30 metres</p>	<p>2. The displayed dimensions as shown on the Dimensions plate (or manufacturer's plate) must be within 5% of the trailer dimensions as presented.</p> <p><b>Masses:</b></p> <p>3. In the case of a trailer subject to Plating, the trailer or axle weights must not exceed the maximums authorised to be issued on the Plating certificate.</p> <p>4. In the case of a trailer not subject to Plating, the trailer or axle weights must not exceed the maximums marked on the Statutory Plate prescribed in section 18 of this manual.</p> <p>5. For a trailer exceeding 3500kg gross weight, or a semi-trailer, it must be verified that the trailer has a facility such that its power brakes can be operated by the towing vehicle.</p> <p><b>Installation of retractable or loadable axles:</b></p> <p>6. If a trailer is fitted with one or more loadable axles, satisfactory evidence must be provided stating that under all driving conditions, the axle will lower to the ground automatically when the front axle or the nearest axle of a group of axles is loaded.</p> <p><b>Turning Circle Requirements: (O3 &amp; O4 semi trailers only)</b></p> <p>7. The trailer combination must be able to manoeuvre for a complete circular trajectory of 360 degrees within the defined area (with the exception of the protruding parts prescribed for the trailer width shown in Annex 1) (See notes 5 &amp; 6, 7, 8 &amp; figure 1)</p>

## Masses and Dimensions 48

Method of Inspection	Required Standard
<p><b>Note 6:</b> A semi-trailer is deemed to comply with the requirements if its wheelbase is not greater than the sum below</p> $\sqrt{(12.50 - 2.04)^2 - (5.30 + L / 2)^2}$ <p>The wheelbase being measured for the purpose of this section is the distance of the axis of the fifth-wheel king-pin to the centre line of the non steering axles bogie</p> <p>L being the trailer width in metres</p> <p><b>Note 7:</b> The following trailers are exempt from standard 7</p> <p>Abnormal Indivisible Load trailer;  A semi-trailer low loader:  A semi-trailer step-frame low loader.</p> <p><b>Note 8:</b> In the case of a semi-trailer designed to carry at least 2 other wheeled vehicles must comply, except that any part of the semi-trailer forward of the transverse plane passing through the king pin may be ignored</p>	

Figure 1

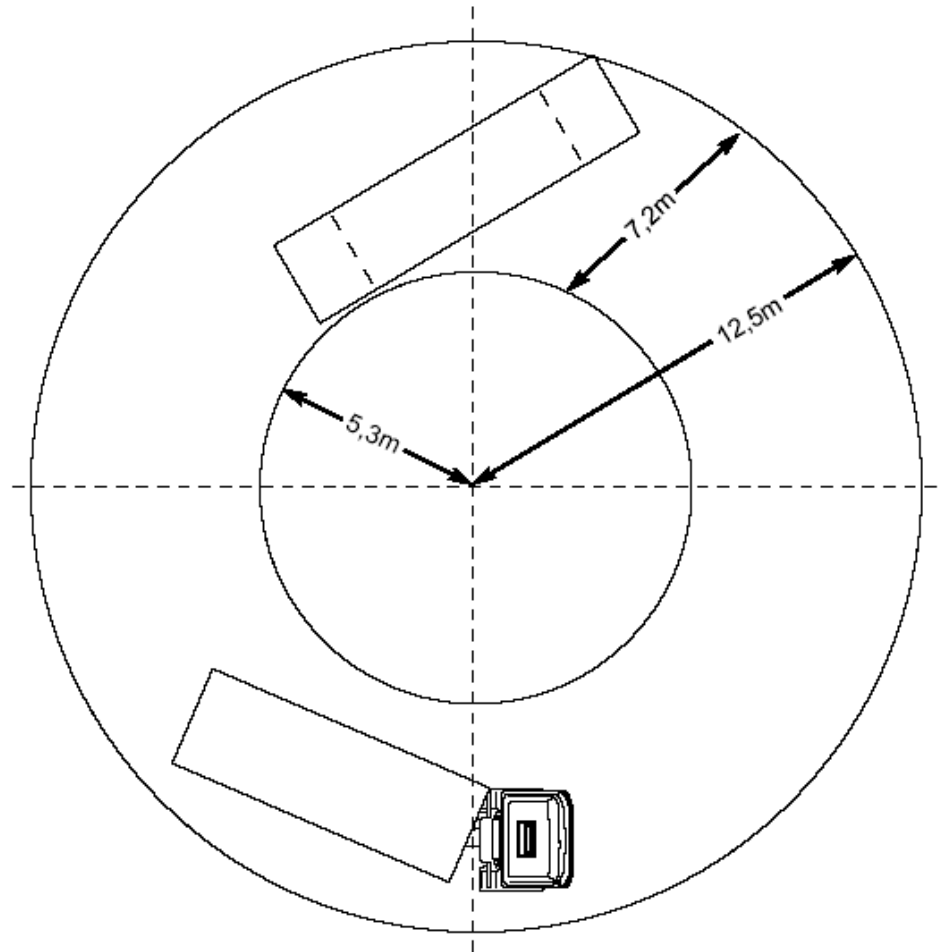

# Masses and Dimensions 48

**Annex 1**

<b>A - Items to be excluded when measuring Length</b>	<b>B - Items to be excluded when measuring Width</b>
<ul style="list-style-type: none"> <li>— rear registration plates,</li> <li>— lighting equipment,</li> <li>— access steps and hand-holds,</li> <li>— lifting platforms, access ramps and similar equipment in <i>running order</i> (i.e. in the position they would be on a moving trailer), not exceeding 300 mm, provided that the loading capacity of the trailer is not increased,</li> <li>— coupling devices,</li> </ul>	<ul style="list-style-type: none"> <li>— tyre-pressure or tyre failure indicators,</li> <li>— protruding flexible parts of wheel guards</li> <li>— lighting equipment,</li> <li>— access ramps in <i>running order</i> (i.e. in the position they would be on a moving trailer), provided that they do not exceed 10 mm from the side of the trailer,</li> <li>— retractable steps,</li> <li>— the deflected part of the tyre walls immediately above the point of contact with the ground,</li> <li>— handles and hinges of external lockers,</li> <li>— trim protruding not more than 10mm from the bodywork,</li> </ul>

**Masses and Dimensions 48**

### Record of Revision

Revision	Date	Description of Change
1	16/04/2009	

# 50A Couplings

**Application:** All O1 & O2 Trailers

Method of Inspection	Required Standard
<p>The coupling device must be accompanied by installation and operating instructions to ensure it is correctly installed and can be operated safely.</p> <p>Check that the correct type of coupling head is fitted to the trailer, normally this will be Class B            Note: Class B coupling heads are permitted for trailers with a maximum mass up to and including 3.5 tonnes</p> <p>Check for the correct 'e' or "E" markings and that the coupling device is installed correctly in accordance with the manufacturer's instructions.</p> <p><b>Note 1:</b> When checking the security of the coupling pay attention to:-</p> <ul style="list-style-type: none"> <li>• The number and grade of securing bolts required</li> <li>• Whether appropriate reinforcement or load spreader plates are fitted.</li> </ul> <p><b>NOTE 2:</b> It may be necessary to have both the trailer and the coupling manufacturers instructions available to ensure assessment of correct installation</p> <p>Check the height of the coupling head above the ground</p>	<ol style="list-style-type: none"> <li>1. The coupling device and mounting bracket (if applicable) must be of an approved class and type suitable for the trailer.</li> <li>2. A secondary coupling must be fitted to all unbraked trailers. Note 3</li> <li>3. The secondary retaining device must be fitted with an attachment device that enables the cable to be fitted to any suitable drawing vehicle</li> <li>4. The secondary coupling must prevent the main coupling from engaging the road surface in the case of detachment from the drawing vehicle</li> <li>5. The coupling device must bear an 'e' or 'E' mark to ensure the construction of the coupling device meets the appropriate approval criteria.</li> <li>6. The coupling device) must be securely mounted to the trailer in accordance with the manufacturer's instructions.</li> <li>7. With the trailer horizontal and resting on a level surface, coupling heads must be attached so that the coupling point of the trailer is 430+/- 30mm above the ground. ( see figure 1)</li> <li>8. The coupling head must be capable of safe operation in accordance with the operating instructions and within the dimensions as shown in the diagram below</li> </ol>

## Couplings 50A

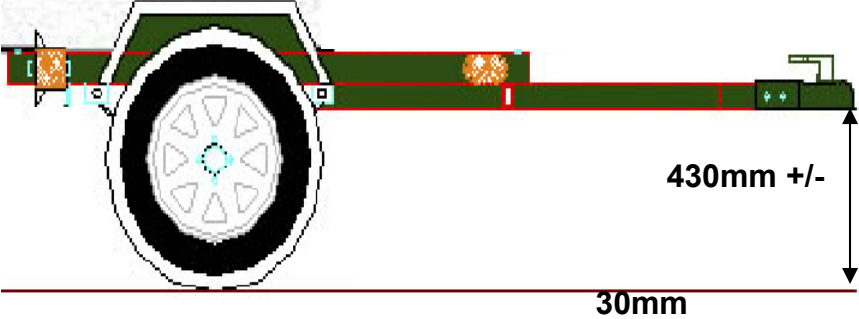
Method of Inspection	Required Standard
<p>Check that a secondary retaining device is fitted to all trailers and is fitted with an attachment device such as a snap clip, carabena or shackle.</p> <p>Check that the coupling head can be operated safely within the free space of the coupling ball shown in diagram in standards.</p> <p><b>Note 3:</b> A secondary coupling can only be used on braked trailers not fitted with a breakaway cable with a maximum mass not exceeding 1.5 tonnes. This cable attaches the trailer to the towing vehicle whilst towing and provides a secondary link. A secondary coupling is a legal requirement for all unbraked trailers.</p> <p><b>Note:</b> In the case of caravans and goods trailers, the horizontal position is regarded as when the floor or loading surface is horizontal. In the case of trailers without such a reference surface, the trailer manufacturer must give an appropriate reference line defining the horizontal position</p>	<p><b>Figure 1</b></p> <p><b>With the trailer level measure the height of the coupling</b></p> 

### Record of Revision

Revision	Date	Description of Change
1	16/04/2009	

This page intentionally left blank

## 50B Couplings

**Application:** All O3 & O4 Trailers

Method of Inspection	Required Standard
<p>This inspection is to ensure that the coupling device is of an approved type, has the correct markings, and is accompanied by manufacturer's installation instructions. Semi trailer support gear (i.e. landing legs) and draw bar adjusting devices should be checked for compliance with RS 4 for semi trailers and RS 6 for drawbar.</p> <p><b>Note 1:</b> The coupling device must be accompanied by installation instructions from the trailer manufacturer and / or manufacturer of the fifth wheel pin, to ensue it is correctly installed.</p> <p><b>Note 2:</b> It may not be possible to fully examine the installation of a fifth wheel coupling pin. In these cases documentary evidence of compliance will be required to confirm compliance</p>	<ol style="list-style-type: none"> <li>1. The coupling device must bear an 'e' or 'E' mark, and be accompanied by relevant installation instructions (See note 1 &amp; 2)</li> <li>2. The coupling device must be designed to work safely at the Max GB gross weight of the trailer, as identified in section 18 of this manual.</li> </ol> <p><b>Semi Trailers</b></p> <ol style="list-style-type: none"> <li>3. The fixing of the fifth wheel coupling pin in the mounting plate on the semi –trailer must be as instructed by the trailer manufacturer and / or manufacturer of the fifth wheel pin. (See note 1)</li> <li>4. Semi trailers must be equipped with secure landing gear or other equipment to allow safe uncoupling and parking.</li> </ol> <p><b>Drawbar Trailers</b></p> <ol style="list-style-type: none"> <li>5. The fixing of the drawbar eye onto the drawbar frame must be as instructed by the trailer manufacturer and / or manufacturer of the draw bar eye.</li> <li>6. The drawbar eye or coupling head on hinged drawbars must rest at least 200mm from the ground when released from the horizontal position.</li> </ol>

## Couplings 50B

<b>Method of Inspection</b>	<b>Required Standard</b>
	<ol style="list-style-type: none"><li data-bbox="1198 236 2094 335">7. If a hinged drawbar is equipped with a device for adjusting the drawbar to the height of the coupling. The device must be able to be operated by one person without any tools or other aids.</li><li data-bbox="1198 371 2094 502">8. For height adjusting devices that provide adjustment for at least 300mm upwards and downwards from the horizontal then the drawbar must be adjustable in steps no greater than 50mm at the coupling or eye.</li><li data-bbox="1198 539 2094 606">9. The height adjusting device must not interfere with easy movement of the drawbar after coupling.</li></ol>

### Record of Revision

Revision	Date	Description of Change
1	16/04/2009	

This page intentionally left blank

# General Construction

**Application:** All Trailers subject to IVA requirements

Method of Inspection	Required Standard
<p>The following section assesses the trailers suitability for use under all normal operating conditions, including when it is laden to its maximum permitted axle/gross vehicle weight and considers the effects of vibrations and the forces imposed by its design speed, acceleration characteristics, braking and cornering. The trailer at all times must present no danger to other road users.</p> <p>All components and attachment methods will be compared to those employed on EWVTA trailers. This does not prevent a manufacturer utilizing other construction methods or materials providing they offer at least the equivalent performance of those employed on an approved trailer.</p> <p><b>Note 1</b> This assessment includes any form of attachments of any component or the assembly of a structure itself, the strength and suitability of materials used including pipes etc and any fastening, welds, bonding, rivets, nuts and bolts etc are to be assessed for their ability to perform their function as intended and must be suitable, complete and fully secured as intended.</p> <p><b>Note 2</b> When assessing a component for leaks the original design of the component will be taken into consideration.</p>	<ol style="list-style-type: none"> <li>1. When towed, the safe control of the trailer must not be impaired or likely to be impaired, due to a design or construction feature of characteristic.</li> <li>2. When towed, the safe control of the trailer or its towing vehicle must not be impaired or likely to be impaired, due to a design or construction feature of characteristic.</li> <li>3. The trailer structure and all components including their attachment must be suitable and of adequate strength. (see note 1)</li> <li>4. A transmission/braking component which rotates during vehicle operation, electrical component, steering or suspension component, wheel or tyre must not foul on another component, or be likely to foul under normal operating conditions.</li> <li>5. Fuel and electrical components must not be subject to either a corrosive environment or be exposed to heat sources likely to cause premature failure.</li> <li>6. All steering, suspension and fuel system component must not be leaking. (see note 2)</li> <li>7. All electrical cables/wires must be free from chaffing and secured at intervals of <b>at least</b> every 300mm unless contained in a secure hollow component.</li> <li>8. All electrical components must be of adequate capacity and insulated as required as to prevent short circuiting during operation.</li> </ol>

## General Construction

# Record of Revision

Revision	Date	Description of Change
1	16/04/2009	

# Glossary of Terms

## Brake Efficiency

Maximum total brake force expressed as a percentage of maximum gross weight.

## Breakaway Cable

A legally required safety device that activates the brakes if car and trailer / caravan become separated in transit. It works by pulling the brakes on then snapping.

## Coupling Class

Class A = Coupling balls and towing brackets

Class D = Drawbar eyes

Class B = Coupling heads

Class G = Fifth wheel Couplings

Class C = Automatic drawbar couplings

Class H = Fifth wheel pin

## Extreme Outer Edge

In relation to the side of a trailer, the vertical plane parallel with the longitudinal axis of the trailer and coinciding with its lateral outer edge, disregard the protection of

- distortion of any tyre due to the weight of the trailer
- connections for tyre pressure gauges
- anti-skid devices mounted on the wheels
- lamps and reflectors
- custom seals and devices for securing and protecting such seals
- special equipment

## Foundation Brake

The foundation brake is the basic drum or disc brake assembly fitted to each axle or wheel which produces the braking force necessary to bring the trailer to a stop.

**Indivisible load**

Shall mean a load that cannot, for the purpose of carriage by road, be divided into two or more loads without undue expense or risk of damage

**Insecure**

A component or its fixing is, due to its design or a construction feature, not completely attached to the trailer structure or to another associated component as intended.

**Lifting Axle**

'Lifting axle' means an axle which can be lifted from the road during normal trailer use.

**Longitudinal Plane**

A vertical plane parallel to the longitudinal axis of the trailer.

**Major Manufacturer**

A trailer manufacturer that provides vehicles approved to EC Whole Vehicle Type Approval standards.

**Manufacturer's Plate**

A piece of durable material e.g. metal or plastic that is likely to last the life of the trailer and which is permanently marked with the required markings.

**Overrun Braking**

The motion of the trailer with respect to the towing vehicle is used to actuate the brake.

**Power Braking**

A system that requires the use of stored energy to operate.

**Rain flap**

'Rain flap' means a flexible component mounted vertically behind the wheel, on the lower part of the chassis or the loading surface, or on the mudguard

**Secondary coupling**

This cable attaches the trailer to the towing vehicle whilst towing and provides a secondary link. A secondary coupling is a legal requirement for all un-braked trailers and braked trailers not exceeding 1500kgs

## Glossary of Terms

### Record of Revision

Revision	Date	Description of Change
1	16/04/2009	

This page intentionally left blank